

# #18 TOP TRUCK

MAGAZINE Spring 2022



[www.toptruck-international.com](http://www.toptruck-international.com)



**#18**  
Spring 2022

# CONTENT

- #04 Editor's note**
- #06 Member news**  
Brazil, Finland, France, Germany, Italy, The Netherlands, Belgium, Poland, Russia, Spain, United Kingdom.
- #14 Industry news**
- #20 Featured member**  
Italy
- #22 In the spotlight**
- #24 Featured suppliers**  
Bosch, Brembo, Clarios, Delphi, Elringklinger, Exide, Febi, Gates, Hengst, Liqui Moly, Mahle, Mann + Hummel, Meritor CV, Metalcaucho, NRF, Osram, Philips Lumileds, Valeo.
- #60 Network contacts**

**THE TOP TRUCK MAGAZINE**  
is published by GROUPAUTO International  
147, avenue Charles de Gaulle  
F-92200 Neuilly sur Seine  
Tel: +33 (0)1 46 37 25 02  
Fax: +33 (0)1 46 37 50 95  
E-mail: [groupauto@groupautointernational.com](mailto:groupauto@groupautointernational.com)

**PUBLISHER:** Holger Hellmich  
**COORDINATION:** Tini Labitzke  
**EDITOR:** Alex Stewart  
**LAYOUT DESIGN:** Comellink - [comellink.com](http://comellink.com)  
**LAYOUT:** Comellink - [comellink.com](http://comellink.com)  
**PHOTOS COPYRIGHT:** Getty Images.  
© 2022 GROUPAUTO International.

All rights reserved.  
Reproduction in whole  
or in part without permission is prohibited.  
Printed by Cifi Laboureur Imprimeur.



# NEW YEAR, NEW OPPORTUNITIES

## We can become even stronger by focussing on our core values

A new year always brings fresh challenges and things upon which to focus. This year, 2022, is no different, except that we are coming out of a period of unprecedented disruption and difficulty. Nonetheless, the message from all our members, and one that resonates throughout this new issue of TOP TRUCK magazine, is that 2022 brings opportunities for our group.

Some of this is building on the successes of last year. There has been strong growth across the network, from Finland to France to the Netherlands. The benefits of adding members are not just the obvious, expanding our footprint and covering more ground. It also brings new voices, new ideas, and new opportunities to discuss and improve our offering. The utility of innovation is also clear from some of the other texts in this issue, with Brazil's continued efforts to harness the power of digital and Poland's foray into EV vehicles, which will bring both new skills and customers.

Meanwhile, the power of collaboration is again obvious, with Germany and Russia working hard to ensure our members can stay in touch, benefit from opportunities to share knowledge and best practices, and stay ahead of important developments in the sector.

Working together, innovating, and communicating are key aspects of any successful business. But the added beauty of belonging to a network such as ours is the depth and breadth of available expertise. And that is how we can, together, forge sustainable and long-lasting businesses, even in challenging times such as these.

This naturally leads on to TOP TRUCK Italy, who are celebrating a decade of successful presence in the aftermarket. It is a huge credit to all the members and suppliers that they have grown and prospered – congratulations!

The continued success in Italy, and of all our members, is testament to the power of our network and of belonging to a group that always emphasises delivering the best to our customers. As the new year unfolds, we look forward to more collaboration, more innovation, and more success.

The TOP TRUCK team wishes you a happy and prosperous 2022.

GROUPAUTO International

EDITOR'S NOTE

GROUPAUTO

# REFERENCED SUPPLIERS

# MEMBER NEWS



**BRAZIL (126 GARAGES)**

## INNOVATION

This year, PitStop TOP TRUCK has taken another innovative step in the aftermarket with the creation of Digital Consulting. This benefit, offered to the network's retailers, has become a reference throughout the Brazilian automotive aftermarket.

The performance of consultants is essential for the network to be able to put into practice processes that transform their business in terms of management. The new reality of the last two years has led to the creation and improvement of remote assistance in the consulting arena, which had been carried out entirely face-to-face. During this period, the network's consultants tracked demand and developed specific materials for remote consulting across the network.

In 2022, the PitStop TOP TRUCK will have a new Digital Consulting system with a specialized team that will provide even more strength, supporting retailers throughout Brazil.

Network consultants are chosen for their potential to add value to a multidisciplinary team with very different and complementary training, skills, and individual competences. Consultants' recommendations to retailers are created, developed, and tested by the PitStop TOP TRUCK team, who have more than 12 years of know-how working directly in the auto parts market.

All this work to improve Digital Consulting has also helped to stimulate the network's process of digital transformation of their business. This will place the network on a new level of management and customer relationship. Currently, PitStop EUROGARAGE and TOP TRUCK combined has more than 1,750 retailers around the country.



**FINLAND (42 GARAGES)**

## A LONG-AWAITED EXHIBITION

The Finnish Power Truck Show 2021 was highly anticipated, as the previous show had been cancelled due to the pandemic. The 2021 event was also affected by the growing number of new Covid cases in the autumn. Over two days, there were around 20,000 visitors and 400 trucks on display.

Koivunen Oy participated in the event by introducing the TOP TRUCK chain. JT-Asunmaa, a repair shop from Alavus, Finland, was there to present its services under the TOP TRUCK banner. The company displayed a cut-through gearbox, which highlighted their speciality in gearboxes and attracted curious visitors. The stand was also visited by many other members of the TOP TRUCK network.

### New member

With its 42 heavy equipment repair shops, the TOP TRUCK network covers the entire country from southern Finland to Lapland.

Koskitraktori Oy, located in Pudasjärvi, Finland, joined the TOP TRUCK chain in November 2021. It is a multi-brand heavy equipment repair shop that performs maintenance

and repair work on heavy transport equipment. In addition to scheduled maintenance, the company specializes in maintenance, repairs, and spare parts for timber cranes from represented brands (Kesla, Loglift, Jonsered, Palfinger, Hiab).

Koskitraktori Oy also offers 10-year inspections of cranes, a comprehensive stock of Parker hydraulic hoses and accessories, sandblasting and all painting work, colour change, body and platform painting, bodybuilding, and various mounting and modification work, as well as maintenance and repair of AC systems.

TOP TRUCK Finland will be present at the following events:

May 5<sup>th</sup>-7<sup>th</sup>, 2022 – MAXPO, Hyvinkää

May 18<sup>th</sup>-19<sup>th</sup>, 2022 – Northern Industry, Oulu

October 12<sup>th</sup>-13<sup>th</sup>, 2022 – Power Truck Show, Härmä

September 1<sup>st</sup>-3<sup>rd</sup>, 2022 – FINNMetko, Jämsä





## FRANCE (206 GARAGES)

### ONE HUNDRED UP!



The Alliance Automotive Group signed its 100<sup>th</sup> TOP TRUCK repairer at the SOLUTRANS Heavy Duty show. Carrosserie Guevel, which is based in Brittany in the west of France and attached to the G-Truck distributor Pilayrou, is the latest addition to the network. Under the direction of Brigitte Cottour, it is the second of the company's establishments to take on the TOP TRUCK colours after Kermat Truck, which joined the network in July 2020.

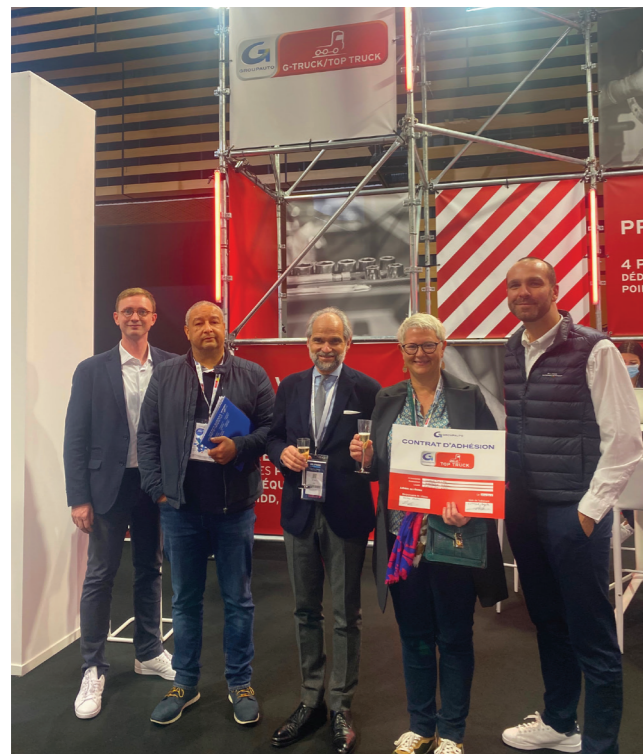

Jérôme Brunner, Director of Heavy Duty Networks at GROUPEAU Alliance Automotive Group, said, "It's always a pleasure for us to welcome into our networks companies as motivated by our project as Carrosserie Guevel. The services offered by the brand and the proximity of our teams to repairers reflects the growth dynamic of TOP TRUCK".

This symbolic signature completes TOP TRUCK's network of repairers in the territory and has allowed the group to establish itself as a leader in the independent aftermarket for the maintenance and repair of industrial vehicles. There are now more than 230 workshops in France.

In parallel with the SOLUTRANS Trade Fair, the G-TRUCK/TOP TRUCK networks brought together their members for their national convention. It happened on November 15<sup>th</sup> at the GROUPAMA Stadium in Lyon, in the south-east of France. The Heavy Duty teams, led by Mr. Brunner, held a plenary session reviewing the major challenges to the network in 2022. Among the issues discussed was training, where last year's results were exceptional, with over 235 days of training provided across the networks.

In addition, the plenary explored audits, crucial to the goal of continuing to be the most efficient multi-brand network in terms of technical competence, networking, and customer service.

The convention also reviewed sector news about braking, diagnostics, and CNG/CNG. Lastly, the launch of the NAPA TRUCK own brand on French soil, and the development of key account agreements, were announced. The convention, which was a huge success for networking and information-sharing, then finished with an evening of festivities. Over 300 people attended the event, a new record since its inception.



## GERMANY (114 GARAGES)

### WORLD OF EXPERIENCE



With the digital trade fair PROFI SERVICE DIGITAL and the industry trade fair PROFI SERVICE TAGE, COPARTS offers its TOP TRUCK workshops two excellent spaces to share and learn information. In addition, affiliated G-TRUCK dealers benefit from a superb sales opportunity.

Both fairs are characterized by high information density and a lot of know-how transfer. At both trade fairs, special offers, some of which are exclusive, will be available to TOP TRUCK partners. PROFI SERVICE DIGITAL takes place during the entirety of May 2022. The exhibition PROFI SERVICE TAGE will be a physical exhibition after a two-year hiatus, due to Covid 19. The exhibition is on 19<sup>th</sup>-20<sup>th</sup>, November 2022 in Exhibition Hall 3 in Frankfurt, open to both exhibitors and trade visitors. The key aim is to remain flexible and accommodate in the safest possible manner any restrictions that may be current at the time of the exhibition.

#### New Regulations

From 2023, the HU Guideline 2014/45/EU aims at increasing transport safety. In vehicles of more than three tonnes, it will have to be possible to check the play of joints in the vehicle reliably. For this reason, all commercial vehicle workshops that offer a main inspection in-house must provide such a guideline-compliant joint play tester;



if not, then officially recognized testing organisations will not be able to offer such inspections. Because of this, it is advisable to plan an upgrade or conversion in good time to be able to adhere to the new guidelines. The reason for this is less the threat of supply bottlenecks and more the need for structural preparations, which take a corresponding amount of time. COPARTS is offering TOP TRUCK partners comprehensive information regarding all requirements and will provide, along with strong workshop equipment partners, practical solutions to conversion or upgrading.



#### A Strong Group

Strong partners are required for success in the very competitive aftermarket. To help with comprehensive access to information for the repair and inspection of commercial vehicles, comprehensive logistics and fast parts supply with UHK Trucks, another G-Truck partner has joined COPARTS. This is the tenth KG company.

UHL Trucks covers north Germany and has 300 employees in seven locations. UHL Trucks will be using the TOP TRUCK workshop concept in further locations. The collective aim is to increase trade in commercial vehicle parts.





## ITALY (182 GARAGES)

Find out how TOP TRUCK Italy celebrated a decade of success in the aftermarket in our Featured Member text



## THE NETHERLANDS (54 GARAGES)

### A BUSY YEAR



Twenty-twenty-one was a huge success for the whole network. Every workshop had enough work and a great turnover. The start of 2022 has also been good, picking up where the network left off in 2021. The only problem now is a shortage of mechanics able to carry out all the work. This is an issue across the country, not just in the network's branches. The main goal for this year is to find enough technicians so that the network can do what it does best, helping the customer to maintain and service their trucks and trailers.

The network has expanded again, though. A new TOP TRUCK Service Partner, Firma JDV in Bitgum, Friesland, has joined in the north of the Netherlands. It is a lovely workshop, situated in an old Volvo dealership building.

Another new TOP TRUCK Workshop is TDC Bedrijfswagens, in Graveland in the middle of the country. This is a particularly good addition as it has proved hard to find the right workshops in that part of the Netherlands. This expansion means there are now 54 members in The Netherlands. It is hoped that this year, this will expand even further.

The network is also delighted that TOP TRUCK Westland was the first winner of the World Class Workshop award! The network is very proud of the team who made this happen and the award was presented in person by Robert Stevens.

There is also a need this year to spend more time with existing members. Due to Covid regulations, there have been far fewer meetings than usual. Obviously, the high level of available work is good, but there must be a renewed focus on what is best for the network, to ensure it stays uppermost in the mind of customers and potential customers. There must be an effort to show them what TOP TRUCK can do for them and why the network would be an excellent partner.

The relationship with RTL Transportwereld has been extended. It is a TV show specially for the Transport sector, with more than 100,000 views every week. The network is also trying to keep in contact with schools for new and motivated mechanics and starting a campaign for recruiting technicians. Without them, the network cannot deliver the services it wants to and this will result in lower sales. The campaign will be on social media and radio, and there is also a special website, [www.toptruckmonteur.nl](http://www.toptruckmonteur.nl)

This year will be an interesting challenge for the network, a transition back to basics to help build for the future. Also on the agenda for 2022 is an exhibition in June, the TOP TRUCK Kartcup in September, and, of course, a new congress.



## BELGIUM (6 GARAGES)

### A BUSY YEAR

In Belgium, as in the Netherlands, the network has had a great year. There has been a lot of work, but this has led to a shortage of mechanics. The main goal for 2022 is to extend the network, filling spots on the map with TOP TRUCK members across the country. This will allow the network to help more customers with great service.

By the time this article is published, it is hoped that the network will be able to say that a representative for the network will be hired. This will help TOP TRUCK members bring in extra work and keep in touch with network customers. Another aim is also to have more standalone meetings within the

network, facilitating cooperation between members. A Kart Cup in Belgium is planned, as well as other meetings.

Education is a further focus for this year in Belgium, with a special program being launched for TOP TRUCK members at a separate training facility. This will allow for more specialist education for members. In addition, a mobile training facility is being set up with a Dutch education firm.

It is a lot of work, but it is all necessary to keep up with developments and to ensure additional value to the network.



## POLAND (14 GARAGES)

### TOP TRUCK GOES ELECTRIC

TOP TRUCK services **OPOLTRANS**  
SIEC HURTOWNI MOTORYZACYJNYCH



TOP TRUCK Poland, in partnership with Opoltrans, one of the biggest European truck parts distributor companies, is entering the EV market. The current network consists of fifteen strong service and repair centres across Poland.

Based on this, Opoltrans has just started a new project, employing the technology and professional knowledge of EVorkshop.com to retrofit vehicles. The business converts combustion engine vans and minibuses into EV vehicles by removing all the old technology modules in the car and installing an electric engine, battery, and all other necessary elements, including software, making it zero-emission.

This activity should generate certain skills and competences among TOP TRUCK teams to prepare them for the new realities of the aftermarket. Soon, they will be able to service retrofitted cars in the same way as car dealers. Additionally, this activity may evolve into the business of EV battery repair.

TOP TRUCK, with trained and experienced personnel, using EVorkshop battery diagnostics and formatting technology, will be able to enter this future market with success.

To work on an industrial scale, there is a strong need to introduce new laws regulating retrofitting activity in Poland. SDCM, the Polish aftermarket association, a member of both Figiefa and Clepa and with significant GROUPEAUTO presence and support, has just started an official initiative to promote such legislation within the government. Such a legal solution already exists in France, so hopefully Poland may be next.





## RUSSIA (14 GARAGES)

### A NEW CONFERENCE

-On December 21st, GROUPAUTO Russia successfully launched its first online truck conference to discuss key topics related to the upcoming developments in the commercial vehicles segment. The event attracted 334 participants and staged some essential conversations.

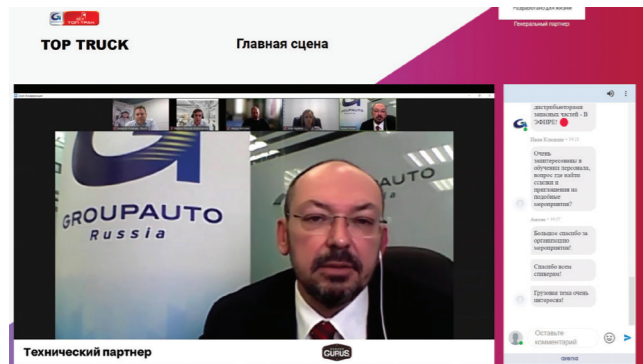

The Conference was divided into three sessions. During the first session, GROUPAUTO Russia's Marketing Director Boris Ageev and the chief editor of the AUTOSTAT analytical agency Sergey Udalov discussed the current state of the Russian commercial vehicles' park and perspectives on its development. Mr. Udalov analysed the dynamics of the 2019-2021 commercial vehicle aftermarket and shared his forecasts for 2022.

The second session saw discussions between commercial vehicles owners and garage directors, the direct participants of the aftermarket. They discussed the market situation from the garages' point of view, explored garages' service expectations of the commercial vehicle owners, and discussed the various factors that might affect the business today.

Within the last session, discussions continued between spare parts manufacturers and distributors. A round table conversation was held, featuring BOSCH key account manager Alexey Ryazanov, Bilstein Group regional sales

manager for the truck segment Viktor Leonov, head of the MAHLE sales department Viktor Kondratyev, KOMTRANS Deputy Development Director Irina Vasilyeva, and TRUCKMOTORS commercial director Fedor Motuzko. Together, they discussed many issues, including the reasons for delays in delivery and the increasing cost of spare parts, the production of new spare parts, technical and marketing support for garages, and warranty policy and corporate customer service's programs.

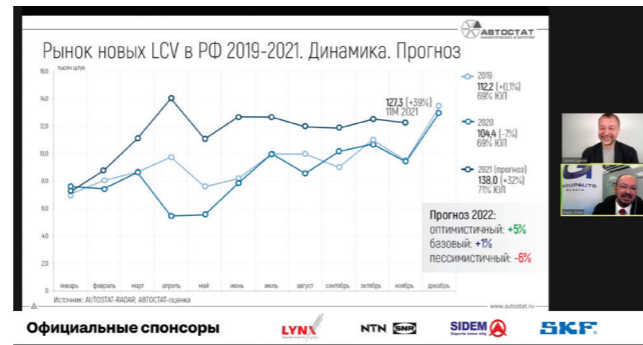

Additionally, on other stages at the Conference, there were workshops for mechanics and master-consultants. These were held by companies including Bilstein Group, BOSCH, DRIV, ELRING, GATES, HELLA, MANN+HUMMEL, MAHLE, NTN-SNR, OSRAM, PHILIPS, TMD FRICTION (TEXTAR и NISSHINBO) and VALEO.

BOSCH was the General Partner of the Conference. BARDAHL, Bilstein Group, GATES, DRIV, KYB, LESJOFORS, MAHLE, NGK Spark Plug, PHILIPS, and VALEO were Official Partners. GARAGE GURUS was the Technical Partner, and LYNX, NTN-SNR, SKF, and SIDEM were the Official Sponsors.

The number of participants and their conversations in the Conference's online chats showed how relevant the event was for many market representatives. The TOP TRUCK Conference has become a great end to a productive 2021. In 2022, GROUPAUTO Russia is planning on holding another truck conference.

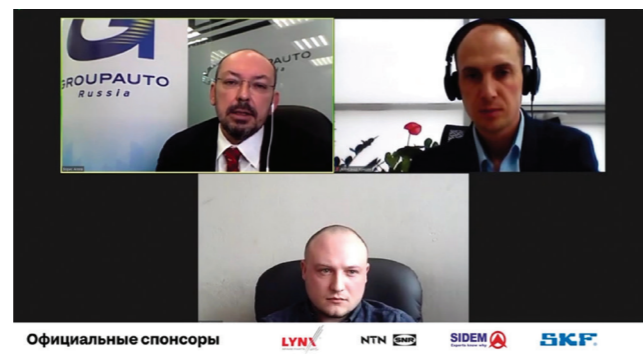
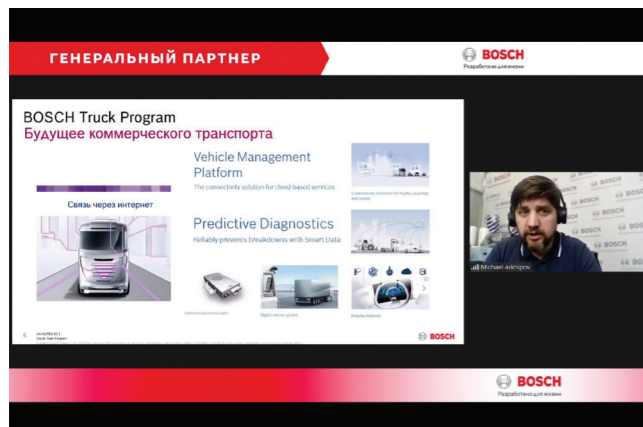

## SPAIN (120 GARAGES)

### NEW PARTNERS



As of January 1<sup>st</sup>, 2022, industrial vehicle spare parts distributors Recambios Industrial Albacete, Hermua Recambios, SGP Global Parts (Portugal), and Global Parts Ibérica have been members of GROUPAUTO Unión Ibérica, which includes the TOP TRUCK network.

With these additions, the network has decisively strengthened its leadership position in the aftermarket, improving its coverage in both Spain and Portugal. GROUPAUTO's broad value proposition has been key in the decision-making of these four companies. They have been able to verify in detail the important

competitive, differentiated, concrete and sustainable advantages that GAUIb offers, both for their companies and for their customers, whether workshops or fleets.

José Moreno, director of the V.I. of GAUIb, said, "Commercial vehicle spare parts distributors face important technological and market challenges that require adequate responses in the short, medium, and long term. Our group is very capable of offering these. GROUPAUTO Unión Ibérica's proposal contributes to the success of our members, thanks to an extensive range of products, brands, and services, including our workshop networks and our innovation in everything digital. For our part, we are delighted with the decision of these four new partners who will shortly begin to deploy our group's tools, programs and solutions."



## UNITED KINGDOM (50 GARAGES)

### CELEBRATIONS

The close of 2021 saw TOP TRUCK UK re-energised with the addition of seven new members joining the garage network. The latest are RCH Commercial in Warwick, Oxford Commercial in Bicester, and Bibby Commercial in Warrington. TOP TRUCK now boasts 52 members throughout the United Kingdom, supported by a large network of 72 CV motor factors.

Last year also saw Driveline GB Ltd add a second site to the growing TOP TRUCK network. Established in 1994 by Mark Kerby and Richard Jacobs, originally as a commercial driver hire agency, Driveline GB Ltd has since evolved into a comprehensive, single-point solution provider. This experience means Driveline can offer a vast portfolio of services from tachograph calibration and repair, commercial garage services, heavy goods MOT testing, CV driver training, and CV vehicle hire, among others.

As well as being a long-standing member, Richard Jacobs has also sat on the TOP TRUCK panel for many years, and the network is delighted to welcome a second Driveline location.

TOP TRUCK was also proud to learn that one of its very own members, Egertons Fleet Services in Wolverton, Milton Keynes was given the 1st Runner Up Award for Marketing in GROUPAUTO International's inaugural World-Class Workshop Awards.

These brand-new annual awards seek to recognise the outstanding achievements of garages throughout Europe



with each TOP TRUCK region submitting their nominees and their area of excellence. These categories included: branding; marketing; customer service; fleet service; and performance.

TOP TRUCK UK is thrilled to see one of its nominations make the grade and it was wonderful for them to receive this accolade. The whole network would like to say a massive congratulations to Egertons Fleet Services for their success.

Members were also able to get 2022 off to a great start with TOP TRUCK branded workshop diaries and wall planners to help boost organisation and plan workflows for the year ahead. These diaries also provide a valuable tool for making a note of those all-important dates such as training courses or CV trade shows.

## BELGIUM

### 50-TONNE TRUCKS ALLOWED ON FLANDRIA ROADS

Since last January, 50-tonne trucks have been authorized to travel on the roads of Flanders. In Wallonia, very large trucks have been able to travel since 2018. “The increase in the maximum load from 44 to 50 tonnes was taken in consultation with the transport sector”, explains Lydia Peeters, the Flanders Minister of Transport. “We are thus making transport more efficient while reducing its impact on the environment. We want to contribute to improving air quality.”

The vehicles will have to meet several strict criteria, such as a distance of 1.30 meters between the axes, and they must be equipped with air suspension. Trucks will need adaptive cruise control and drivers will have to maintain a distance of 15 metres from other vehicles, including in traffic jams.



## WINTER DRIVING

### WINTER REGISTRATION ENHANCED IN FRANCE AND NORWAY

Since November 1<sup>st</sup>, heavy goods vehicles traveling in French mountain ranges during the winter period are required to have snow chains, even if they are fitted with winter tires. At the same time, in Norway, European drivers will soon have to pass a ‘winter license’.

According to the Norwegian Transport Federation, many drivers do not know how to drive on icy roads. Every year, this causes major blockages. Political parties in Norway have sought action on this policy since 2014, and the new government, elected last September, has therefore decided to enact a law.

## EUROPE

### HOW TO PROMOTE HYDROGEN TRUCKS

A study entitled “Hydrogen in the road freight transport sector” has been published by the Équilibre des Énergies (EdEn) association to promote hydrogen. “Heavy goods vehicles were the source an estimated 31.5 Mt of CO2 emissions, 98.7% of which came from diesel engines, or 24.7% of total road transport emissions in 2019”, observed Jean-Pierre Hauet, President of the Scientific Committee of Équilibre des Énergies.

To measure the possibilities for development of the hydrogen sector, the study assessed two scenarios. The first looked at a scenario where hydrogen dominates up to 65% of European long-distance transport. In this case, “hydrogen takes a 10% market share in journeys of less than 150 km and of 30% in journeys of 150 to 500 km.” A second scenario looked at when hydrogen does not become a majority fuel and where its market share in transport over 500 km peaks at 25%. “In both cases, growth is not linear, and in 2030 the penetration of hydrogen remains limited, given the delays in the construction of infrastructure and the migration of truck fleets to hydrogen”, the study summarizes.

This growth could find traction more quickly than expected because “the proposal of the European Commission, made public on July 14<sup>th</sup>, 2021, goes in this direction. It provides that States will have to equip the trans-European transport network with hydrogen distribution stations spaced apart by at most 150 km, with a capacity of 2 t/day for gaseous hydrogen at 700 bars, and 450 km for liquid hydrogen”, claims the study.



## SOCIAL

### DRIVER SHORTAGE IN EUROPE

The whole of Europe is affected by a severe labor shortage, with an estimated deficit of 400,000 drivers across the continent. With 124,000 jobs to be filled, Poland is the most affected, according to Transport Intelligence. Carriers must compete to attract, retain, and train their future drivers, with the help of the European Union. Great Britain is in second place (60,000 to 76,000 drivers needed), followed by Germany (45,000 to 60,000). France is in fourth position in the TI classification, with 43,000 positions to be filled.



## ENVIRONMENT

### GNL VS DIESEL TRUCKS

According to tests commissioned by the NGO Transport & Environment, LNG trucks have no effect on CO2 emissions and emit more carcinogenic particles. The Technological University of Graz (TU Graz) compared an Iveco S-Way LNG truck with its diesel equivalent (on a Stralis), by measuring the emissions of carbon dioxide (CO2), nitrous oxide (N2O), and methane (CH4), both in the exhaust pipes of the two models and during the fuel production stages.

TU Graz then calculated the amount of GHGs that remained in the atmosphere for twenty years and a hundred years after emission. It shows that an LNG truck emits, on average, 13.4% more GHGs, in twenty years, than a truck equipped with a diesel engine. This surplus is not due to exhaust emissions, since an LNG truck emits less CO2, almost no N2O and only slightly more methane than its diesel equivalent. It could instead be explained by leaks of methane produced during the extraction of natural gas and the GHGs emitted by tankers transporting LNG and during the liquefaction of natural gas into LNG.

## ROADS

### SURFACE HEATING TESTED TO PRESERVE GERMAN ROADS

German highways are subject to extreme temperature variations. The salting on light holes made by the frost in winter adds to the deterioration of pavements. To combat such damage, the company in charge of road management, BAST, will test various systems of heating under asphalt on a section of the motorway around Leverkusen.

A test portion of the 25,000 square meter motorway will be used for the experiment around the Leverkusen interchange. Different air conditioning techniques will be tested. Two test sections will be equipped with heating cables under the asphalt, using the model of classic underfloor heating. Three other sections will test a new technique: the use of rubber granules bound by polyurethane (instead of bitumen granules), allowing water to circulate under the construction. This technique has the advantage of simplifying the work and the materials are easier to recycle than with conventional underfloor heating.

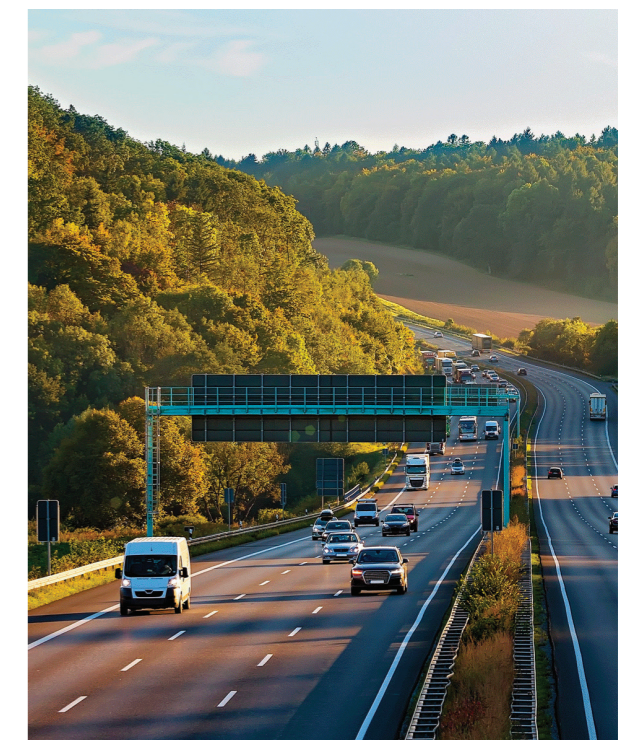



SECURITY

## PARKING AREAS: €100 MILLION FUNDING FROM THE EUROPEAN COMMISSION

The European Commission has launched a call for proposals to access funding of €100 million under the Connecting Europe Mechanism (CEF). Investment priorities include the development of new SSTPAs (Network of Safe and Secure Truck Parking Areas) and the modernization of safety, security, and services at existing rest areas. There are only 300,000 parking spaces for trucks currently available in the European Union. Some 100,000 additional spaces would be needed to meet total demand. Moreover “only 7,000, or less than 3%, of existing spaces in the EU are in certified safe and secure areas,” said a report.



AUTONOMOUS TRUCKS

## DAIMLER TRUCK AND TORC ROBOTICS ON THE ROAD TO AUTONOMOUS DRIVING

Daimler Truck and Torc Robotics are kicking off their third year of collaboration by testing the next generation of 4-level autonomous trucks. This new generation of test trucks incorporates more sensors at higher resolutions to improve detection of objects at greater distances.



SPAIN

## STANDARDISATION OF SPANISH TOLLS IN 2024

In an article published by the Catalan daily La Vanguardia, on August 29<sup>th</sup>, the new Minister of Transport, Raquel Sanchez, confirmed the establishment of ‘pay-as-you-go’ tolls on main roads (10,500 km). This is a commitment from the Spanish government to the European Commission, linked to obtaining significant community financial support of €140 billion. An inter-ministerial working group is currently working on the concrete terms of the new system, which should be applied to all users (individuals and carriers), from 2024.



FRENCH ROADS

## IN 2025, ONLY 44-TONNES EURO 6 WILL ALLOW TO CIRCULATE

In France, a recent decree has stated that from 2025, for vehicles with four axles and weighing more than 44 tonnes, it is mandatory that these vehicles first entered service on or after 1<sup>st</sup> January, 2014, or are of the Euro 6 type.



AUSTRIA

## ELECTRIC TRUCKS POWERED BY THE SUN

In Vienna, Swedish furniture dealer Ikea has received 30 Q-Light Quantron electric vans which will enable it to deliver to its customers in the Austrian capital without CO<sup>2</sup> emissions. The electricity that will power these vehicles comes from photovoltaic panels, which provide 100% renewable energy. The all-electric Q-Light underwent extensive testing. With a range of approximately 170km, a driving power of 100kW and a maximum charging power of 70kWh, it will be able to deliver to customers in the 23 municipalities of the Vienna agglomeration within a 30km radius of the logistics center.



EUROPE

## BRUSSELS AUTHORIZES THE RENTAL OF TRUCKS FOR TWO MONTHS

Renting a truck without a driver within the European Union is now possible for a period of two months. The European Parliament and Council have agreed on a simplification of rental procedures. In future, Member States can authorize their transporters to rent, for a minimum period of two months, trucks in another Member State. The new regulations limit the number of trucks rented abroad to 25% of the fleet. Currently, self-driving truck rental regulations vary widely from state to state. Thirteen countries, including Germany, require carriers to register vehicles rented for more than 20 days. Five countries, Austria, Ireland, Luxembourg, Denmark, and Slovenia, allow a 30-day deadline. Eight impose immediate registration, while in Spain, the rental of trucks in country A to transport goods from country B to country C is simply prohibited.

SAFETY

## THE NETHERLANDS BANS SMOKING WHILE DRIVING

Smoking has been banned in the workplace in the Netherlands from January 1<sup>st</sup>. For truck drivers, this translates into a ban on smoking while driving. Penalties can be anywhere between €450 and €450,000. The Netherlands thus joins Italy, which has also banned smoking while driving, but for a completely different reason: while the Netherlands emphasizes the right of employees to have a smoke-free workplace, Italy insists on the risk of losing concentration at the wheel, linked to the use of tobacco.

## AUTONOMOUS TRUCKS

**ARRIVAL TESTS  
AUTONOMOUS DRIVING**

The Britain company Arrival said its electric van performed well in its first autonomous driving test in a warehouse. The British startup now intends to test this feature on the open road in the United Kingdom and continues to garner orders. For now, Arrival has managed to develop its autonomous driving systems up to SAE level 3 (the driver must be able to get behind the wheel at any time) and must continue to work to reach level 4 which would allow for fully autonomous driving for certain parts of a journey.

Arrival is due to start production of its large-scale vans and buses in the third quarter of 2022. UPS, a shareholder in the company, has reserved 10,000 units to join its European and North American fleets by 2024. The long-term management specialist LeasePlan has also signed an initial pre-order for 3,000 vans.



## HYDROGEN TRUCK

**HYZON TO DELIVER WORLD'S  
LARGEST HYDROGEN HEAVY-  
DUTY TRUCKS TO AUSTRALIA**

Hyzon Motors, one of the world's leading fuel cell utility vehicle suppliers, said it had received an order to deliver five 154-tonne hydrogen-fueled trucks by the end of 2022 to Australia, with a 140-tonne capacity, which would make the world's largest fuel cell trucks. The order is for Ark Energy Corporation, the Australian subsidiary of the world's largest producer of zinc, lead, and silver. The project plans to deploy them in a triple road train with three trailers to complete a 30 km loop from the port of Townsville, Queensland. The fuel cell trucks, which will replace their diesel equivalents, are expected to reduce carbon dioxide emissions by more than 1,400 tonnes per year. Hyzon will also deliver 10 hydrogen buses to an Australian mining group after conclusive tests showed that the vehicles had a range of 800 km in grueling heat conditions.

Three leading commercial vehicle manufacturers, Daimler Truck, the TRATON GROUP, and the Volvo Group, have signed a binding agreement to create a joint venture to install and operate a high-performance public charging network across Europe for battery and electric, heavy-duty long-haul trucks and coaches. The planned venture, to be equally owned by the three parties, is scheduled to start operations in 2022 following the completion of all regulatory approval processes. The parties are committed to investing €500 million together, which is assumed to be by far the largest charging infrastructure investment in the European heavy-duty truck industry to date. The plan is to install and operate at least 1,700 high-performance green energy charging points on and close to highways as well as at logistic and destination points within five years of the establishment of the joint venture.

## CHARGING NETWORK

**DAIMLER TRUCK, TRATON  
GROUP, AND VOLVO  
GROUP SIGN UP FOR EU  
HIGH PERFORMANCE  
CHARGING NETWORK**

## ELECTRIC ROADS

**ELECTRIFIED MOTORWAY  
TESTED IN THE FRANKFURT  
REGION WILL BE EXTENDED**

The electrified motorway project has been extended to western Germany. The infrastructure will be extended by 7 km on the A5 motorway between Hesse and Basel, to a total of 17 km. Five hybrid trucks run on a regular line. The project is seen in Germany as a possible alternative to conventional trucks to meet climate targets. Five carriers are currently each testing a hybrid truck specially fitted out by Scania. The project, called ELISA, aims to verify the environmental (particularly in terms of emissions and noise pollution) and economic advantages of trucks equipped with poles connected to overhead electrical wiring on the motorway. Vehicles can thus recharge their battery while driving. At any time, the driver can leave the electrified track and switch to diesel supply once his batteries are discharged.



## TEST

**GERMAN JOURNALIST  
CHECKS VOLVO FH ELECTRIC  
RANGE**

The first independent consumption test on a fully charged Volvo electric truck has been carried out in Germany. The truck tested was a Volvo FH Electric, a zero-exhaust vehicle, with a continuous power of 490kW and a GCW of 40 tonnes. German trucking journalist Jan Burgdorf put the FH model through its paces on the Green Truck Award course, a 343 km long route consisting of a combination of motorways, rough terrain and winding roads, used to test trucks from different manufacturers in a variety of conditions. The Volvo FH Electric managed to maintain an average speed of 80 km/h over the entire route, similar to the Volvo FH equipped with a diesel engine and the I-Save system which improves fuel economy. The total range of the electric truck was 345 km after one charge.



## TECHNOLOGIES

**MAN OFFERS REMOTE  
MAPPING UPDATE**

Thanks to Over-the-Air technology, all MAN trucks equipped with the OnlineTraffic truck navigator can now benefit from a remote map update. MAN OnlineTraffic integrates real-time data on the traffic situation into the vehicle's navigation system, taking into account the special requirements of heavy goods vehicles. It allows the driver to receive real-time information on traffic jams, works, diversions, and other disturbances. Now, thanks to this technology, updates to can be done remotely and even on the move, avoiding vehicle downtime.



## SOFTWARE

**NEW ANALYTICS TOOL TO  
REDUCE CO<sup>2</sup> AMOUNTS**

HERE Technologies has announced a new commercial fleet analytics tool that predicts the amount of CO<sup>2</sup> emissions per route, considering factors such as vehicle and fuel type, traffic conditions and the road network's physical attributes, including topography, curvature, slope, and elevation. CO<sup>2</sup> Insights also recommends the most appropriate commercial vehicle with the most appropriate engine (diesel, electric, bio-gas or hydrogen) to produce the lowest emissions for any given route.

# FEATURED MEMBER

ITALY

## A DECADE AT THE TOP



In 2011, the Truck Company Group created the TOP TRUCK network in Italy and now, with great pride, it has reached its first important anniversary, 10 years! If today being part of the network is synonymous with reliability, competence, and a customer-driven mentality, it is thanks to all those who believed in and supported the project from the beginning.

To celebrate this first decade of the network, a celebratory trophy was created that was delivered by the Truck Company Group to all those workshops that had joined the network back then and are still part of it today. They are the foundation of the organization.

The same trophy was also given to those suppliers who have supported the Truck Company Group for ten years. If the network has come this far, it is also thanks to such precious contributions and a close cooperation over the years. These suppliers have always tried to accommodate almost any need or desire, and made available their knowledge, skills, resources, and ideas.

In addition, G-Truck members who have been part of the Group since 2011 have been recognised with this award. They are CFF, CORIND, DEVOTO, EUROVEICOLI and EXPERICA (a company born from the merger of the two historical partners Revarc and Tecnauto-car). Those five G-Truck members, plus the two more recent additions CASERTANO RICAMBI and SALAMONE, have grown with the network and are the cornerstone of the organization.

Finally, to celebrate this first decade, a “TOP TRUCK Award” was launched to recognise those workshops that have distinguished themselves in recent years, in two areas particularly: roadside assistance and brand awareness.

Thanks to the agreements Truck Company Group has signed with some European road service companies, it has been possible to verify the number of road interventions made by the workshops and thus reward the most proactive ones in roadside assistance. And for the second category, TOP TRUCK brand awareness, awards went to those workshops who have personalized vehicles, websites, social media, and have done activities to promote the logo.

Despite the difficulties brought by 2021, TOP TRUCK Italy has started the new year feeling proud and happy, recognising the achievements of the past decade and looking forward to celebrating the next in 2031!



Officina Beccaro received the “Road Side Assistance” plate



Officina TN SERVICE received the “Brand Awareness” plate



Officina Pandolfini received the “10 year” trophy and the “Road Side Assistance” plate



EFFECI SERVICE were recognised with the trophy and both awards

# IN THE SPOTLIGHT

Author : Robert Stevens, Director of Garage Networks & Technology

## WORLD CLASS WORKSHOP AWARDS



In 2021, GROUPAUTO International launched the World Class Workshop Awards. This award was created to recognize outstanding workshops in our EUROGARAGE and TOP TRUCK networks. To determine the winner, we contacted the various Network Managers from our international networks and asked them to nominate workshops in five categories.

The Network Managers were asked to provide supporting information to help GROUPAUTO International select the winners in each category. We received a range of information including workshop images, marketing materials, and customer feedback. After reviewing this information, and the input from the Network Managers, GROUPAUTO International selected a 2<sup>nd</sup> Runner-Up, 1<sup>st</sup> Runner-Up, and Winner for each category.

The Category Winners were selected from more than 1,000 TOP TRUCK workshops in 17 countries. Below are the 2021 TOP TRUCK Category Winners and Runners-Up. These workshops excelled in one of the five individual categories: Branding, Marketing, Customer Service, Fleet Service, and Performance.

Congratulations to the TOP TRUCK Category Winners and Runners-Up!

TOP TRUCK	Branding	Marketing	Customer Service	Fleet Service	Performance
<b>2<sup>nd</sup> Runner-up</b>	<b>Spain</b> Talleres J. Carrasco	<b>Italy</b> TT Officina Mimo	<b>Italy</b> Effeci Service	<b>Portugal</b> TT Basyf	<b>Italy</b> TT Mantovan
<b>1<sup>st</sup> Runner-up</b>	<b>Portugal</b> TT Simões & Simões	<b>UK</b> Egertons	<b>Portugal</b> TT Autoengenhocas	<b>Finland</b> Truckshop Häggblom Ab Oy	<b>Spain</b> Reviplas
<b>WINNER</b>	<b>Italy</b> TT Bortolameazzi	<b>France</b> Garage MPL	<b>Spain</b> Talleres Aragoneses	<b>Spain</b> Electromecanica La Loma	<b>Portugal</b> TT Juncauto

The categories included:

- World Class Branding
- World Class Marketing
- World Class Customer Service
- World Class Fleet Service
- World Class Performance

GROUPAUTO International then selected the Winner and Runners-up for the top award of WORLD CLASS WORKSHOP 2021. To win this award, the workshop had to excel in all five individual categories.



Congratulations to the 2021 TOP TRUCK World Class Workshop Winner, TOP TRUCK WESTLAND from the Netherlands, as well as the Runners-Up, TOP TRUCK MECALEV from France and TOP TRUCK SIMÕES & SIMÕES from Portugal!

WORLD CLASS WORKSHOP	
<b>2nd Runner-up</b>	<b>Portugal</b> TT Simões & Simões
<b>1st Runner-up</b>	<b>France</b> TT Mecalev
<b>WINNER</b>	<b>Netherlands</b> TT Westland

2021 is the first year GROUPAUTO International has presented the World Class Workshop awards. Based on the success of 2021, the World Class Workshop Awards will continue annually. We will be asking our Network Managers for new nominations later in the year, and we look forward to even more workshops being nominated for this award in 2022.

The purpose of the TOP TRUCK Network is to maximize the opportunity for aftermarket commercial vehicle workshops and to maximize the value of these workshops to commercial vehicle owners and fleet operators. We are working to accomplish this through standardization, integration, and cooperation throughout the network. It is vital that we transition from being a collection of independent national networks to being a single international network. This is what will allow us to compete in the future.

The World Class Workshop awards not only recognize some of our outstanding workshops, but also provide us with a benchmark for what our international network can achieve.

Congratulations again to all the TOP TRUCK Winners and Runners-up for 2021, and I look forward to the 2022 World Class Workshop awards.





## DENOXTRONIC: Comprehensive Bosch range for CVs



Replacing a Bosch supply module on a truck

In 2004, Bosch first offered Denoxtronic solutions for commercial vehicles. Ever since, five generations of Denoxtronic exhaust-gas treatment and dosing systems have been installed on most diesel vehicles. This system injects a watery urea solution (known as AdBlue) into the exhaust stream. In combination with the SCR catalytic converter, this turns

harmful nitrogen oxides (NOx) into water and nitrogen. Today, approximately 12 million of these systems are used in trucks, construction and agricultural machinery as well as stationary units with diesel generators worldwide. That's a huge potential for commercial-vehicle workshops to generate additional turnover.

After all, professionally used commercial vehicles need to be serviced regularly in order to achieve a long service life and high mileages. This results in a high demand for servicing at the workshops.

### THE COMPLETE BOSCH DENOXTRONIC RANGE

Bosch supplies a comprehensive range for Denoxtronic maintenance and repair at commercial-vehicle workshops

- ▶ Diagnostic equipment
- ▶ ESI[tronic] workshop software
- ▶ Supply and dosing modules
- ▶ Bosch eXchange range of replacement parts
- ▶ Spare parts and tools for field repair of individual components
- ▶ Denoxtronic filters
- ▶ Exhaust-gas sensors
- ▶ Technical trainings



Modern Denoxtronic 2.2 supply module

### BOSCH DENOXTRONIC SERVICE RANGE

Bosch offers a comprehensive range of services to meet the demands of this highly complex market. Denoxtronic test kits and KTS Truck diagnostic devices can be used to test the components of Denoxtronic exhaust-gas treatment systems without having to remove them and right on the commercial vehicle. Reliable identification of defective modules allows for quick and suitable service solutions. This can, for instance, be the replacement of



### Professional field repair

defective modules – from the range of the new parts program or the Bosch eXchange replacement parts program. Another solution might be Denoxtronic field repair. For this purpose, the Bosch range includes a variety of components and repair instructions as well as logical and easily performed tests.

Featuring many years of Original equipment experience and competence, Bosch is able to provide test equipment, software, modules, sensors and filters for efficient and time-saving servicing – from a single source and for any workshop.



## Driven by EXPERIENCE



### Better performance for the workshop

Denoxtronic diagnosis, replacement and service for experts – The comprehensive range of services for exhaust-gas treatment.

[boschaftermarket.com](http://boschaftermarket.com)



[bremboparts.com](http://bremboparts.com)

OUR PRIORITY IS MAKING ALL DRIVERS SAFE  
 OUR PRIORITY IS MAKING ALL DRIVERS SAFE  
 OUR PRIORITY IS MAKING ALL DRIVERS SAFE



**EVERY CAR DESERVES BREMBO**

**The widest range, guaranteed by Brembo**  
 Our comprehensive state-of-the-art range of brake pads, discs, drums, shoes, hydraulic components, remanufactured calipers and brake fluids, is the safest choice. We plan beyond the essential, because every vehicle deserves Brembo safety standards.



Long lasting  
**journeys**  
 begin here

**New technology for trucks.  
 Uniquely made by Brembo.**

Easy decision. From the Brembo OE assembly directly in our premium packaging, give your wheels the kind of quality they are used to.

With the same reliable 100% inhouse production as the original equipment components, Brembo ensures supreme quality replacements for IVECO, MAN, MERCEDES-BENZ, SAF-HOLLAND, SCHMITZ CARGOBULL, VOLVO and many others. So, whatever part you're replacing, replace it with the authentic one. There is nothing better.

For drivers of trucks and heavy goods vehicles who never settle for just the ordinary, unique in the Independent Aftermarket and offering better all-round resistance for enhanced performance and longer life. With certified quality assurance, for peace of mind in every drive. It's the ultimate Prime replacement part, for vehicles made to go further.

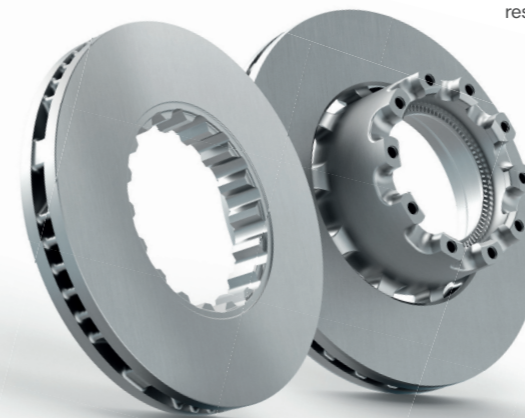

- Innovative solutions
- Superior resistance
- Long lasting durability
- Full range

[bremboparts.com](http://bremboparts.com)

TESTED AND TRUSTED ALL OVER EUROPE.

# WHY AGM TECHNOLOGY IS A MUST HAVE FOR MODERN TRUCKS?



Original equipment manufacturers and logistics companies demand proven high-quality equipment. The VARTA® ProMotive AGM represents a significant breakthrough in commercial vehicle battery development. Using the latest AGM technology, this innovative product meets and surpasses all requirements. But what makes the VARTA ProMotive AGM so unique?

Heavy commercial vehicles have changed significantly over the past years. Advanced fuel saving and comfort-functions along with new governmental regulations and the ongoing changes in driving profiles (reduced driving and extended idle time, and overall more time spent in the trucks) impact the battery in many ways, making high vibration resistance, fast recharging, and a large cycle life along with an increased depth of discharge an absolute must. That is why the VARTA ProMotive AGM is the battery of choice for all major manufacturers when it comes to equipping their commercial vehicles.

### Absorbent Glass Mat meets PowerFrame grids

What makes this battery so special? It's in the name; "Absorbent Glass Mat" or in short "AGM". This fleece material soaks up the acid in the battery like a sponge, providing the highest cyclic stability. Since there is no acid stratification, the biggest killer of conventional batteries, overall capacity loss is reduced to a minimum, resulting in a much longer life compared to conventional batteries.

A unique feature of VARTA AGM batteries is the patented PowerFrame® design. The VARTA ProMotive AGM is the first battery to use this special grid on both the positive and negative plates for optimum performance and excellent starting characteristics even at low charge levels.

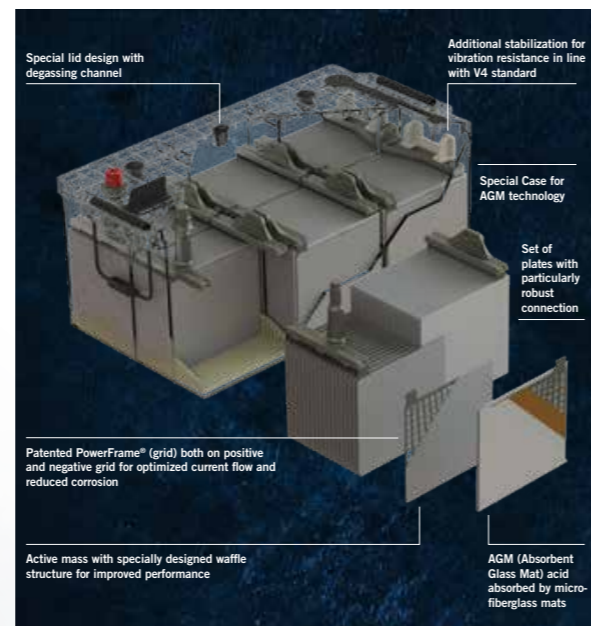

The unique components allow the AGM battery to be repeatedly charged and discharged without any loss of performance.

PowerFrame® grid technology is nearly three times\* more corrosion resistant than other grid designs and provides more than 60%\* superior electrical flow for better connectivity.

### Charging cycles and cycle depth

With the increasing number of electrical consumers, the importance of depth of discharge (DoD) is growing. Due to the special design the VARTA ProMotive AGM can be discharged by up to 80% without significantly compromising cycle life, which is a key requirement for state-of-the-art commercial vehicles equipped with fuel saving and advanced hoteling functions. In comparison, for conventional starter batteries a maximum of 20% discharge is recommended to achieve a proper field life.

\*Based on comparison to other grid designs in real world fleet testing.

The cycle life is a crucial performance indicator in energy demanding applications. It defines how many times a battery can be discharged and recharged before it reaches its end of life. The VARTA ProMotive AGM can stand six times more cycles compared to conventional batteries. With its cycling stability and depth of discharge capabilities AGM is the perfect technology for commercial vehicles that need to supply many electrical consumers during break times and even longer periods like overnight stays.

"This is especially useful for our company. Aside from the usual comfort functions and fuel saving systems, our trucks have fleet telematics on board. It gathers valuable data using a combination of GPS technology, sensors, and onboard diagnostics. All of which must be powered when the truck is driving and parking", explains Krystof Leporowski, Senior Service Technician at Poland-based logistics company Elkor Transport.

### Charge acceptance – a critical factor for conventional batteries

"AGM technology allows the batteries to deliver more energy, while at the same time absorbing more charge – meaning this battery will be fully charged within a few hours." says Thorsten Werle, Engineering Design Lead Heavy Duty at Clarios EMEA, referring to another feature of the battery, the charge acceptance. This is the ability of a battery to accept and store energy considering factors like temperature, state of charge, charging voltage or battery history. The VARTA ProMotive AGM provides a much better charge acceptance than conventional batteries. That means the battery is recharging faster e.g. a half-discharged AGM battery can be recharged to 90% in only one hour and is

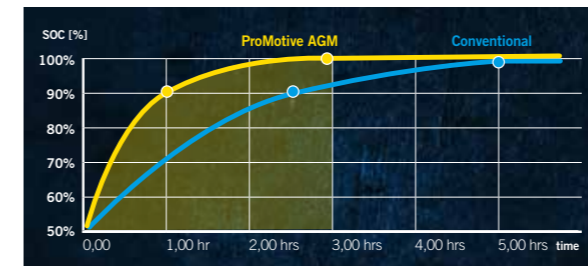

The AGM can go from 50% to 100% state of charge (SOC) much faster than conventional batteries.

fully charged after less than 3 hours of driving. In comparison, a conventional battery needs 2.5 hours to reach the 90% and more than 5 hours for a full charge. These batteries can often not be fully recharged due to the low charge voltage in the vehicles. In comparison to conventional batteries AGM batteries are more efficient with low charge voltage and can be recharged entirely.

A major reason for the gradual deterioration of charge acceptance is acid stratification, which is the accumulation of sulfuric acid at the bottom of the cell. This leads to faster sulfation of the plates, reduced capacity, and hence eventually battery failure. There is no stratification in an AGM and consequently no shift in voltage that goes along with it. With the help of the PowerFrame® design, an AGM generates more than enough power for excellent starting characteristics even if the charge level is low and the depth of discharge is correspondingly high.

### Reliable and built to last

In many modern trucks AdBlue tanks and larger fuel tanks are displacing batteries towards the rear end of the frame. In this position, they must be able to withstand increased vibration and shocks but are also stressed by unwanted oscillations and resonances. With conventional technology, the continuous stress can considerably reduce the battery's life.

"In the past, we had to replace about one third of our batteries due to severe damage. Therefore, we needed more efficient batteries with extended lifetime and reliability", recalls Leporowski.

### New requirement for long-distance trucks

For commercial vehicle batteries to meet the requirements of modern long-distance goods transport the European battery standard EN50342 has been revised. The new directive V4 achieves a better approximation to real-life operation. Batteries must now withstand a five-hour vibration test in each three spatial axes over a frequency spectrum from 5 to 100 Hertz. What sounds complicated is basically a test simulating most extreme conditions for batteries in real life. Only a few products on the market have the ability to bound electrolyte, have enhanced fixations and have durable injection molded cases, making them the most robust solution.

### Ready for the next generation

VARTA AGM is the manufacturer's choice when it comes to fitting the best battery technology available – today and in the future. Leading original equipment manufacturers even consider the VARTA ProMotive AGM for the coming E-Trucks. In full-electric vehicles, the AGM battery plays a major role in supporting the low voltage board net architecture. It supplies the vehicle's electrical system and secures that safety-relevant functions like lighting, brakes, steering and systems in the cab are working properly even during an outage of the high-voltage-system. For E-Trucks and for future safety systems (like autonomous driving) vehicle manufacturers are convinced that the VARTA ProMotive AGM battery is a perfect fit for these applications.

### VARTA Fleet Program: direct contact to the manufacturer

The increasing complexity of modern trucks represents a major challenge for trucking companies. To ensure that fleets are best equipped to cope with these, VARTA has not just developed a reliable, future-ready product in the form of the AGM battery, but also offers the corresponding service with its VARTA Fleet Program. This program's main feature is that it offers fleet managers direct contact to Clarios.

By registering free of charge on the website [www.varta-partner-portal.com/en-GB/fleet-program](http://www.varta-partner-portal.com/en-GB/fleet-program), members will receive custom advice relating to their fleet, strategic purchase recommendations, support on battery management-related questions, analysis and optimization options for battery performance and a great deal more.

### Clarios Germany

Am Leineufer 51, 30419 Hannover

[www.varta-partner-portal.com](http://www.varta-partner-portal.com)



# Delphi Technologies

## Discover the next generation of diagnostics

Delphi Technologies Aftermarket, a brand of BorgWarner Inc, grows its diagnostic portfolio with an innovative, easy to use analytic tool providing workshops with an extensive suite of diagnostic interrogations, real world data, and more. The previous Vehicle Communication Interface (VCI) tool will still be fully supported within the diagnostic range to offer workshops choice and flexibility in finding a diagnostic solution which meets their needs. This newly designed unit joins Delphi Technologies' diagnostic line up at an exciting time focused on pioneering the best diagnostics in the market.

### DELPHI TECHNOLOGIES' LATEST VCI FORGES THE PATH FOR EVOLUTION OF WORKSHOP DIAGNOSTICS

The new **BlueTech VCI** is designed from the ground up to meet the changing aftermarket world. Its originality is evident from its external characteristics alone. An LED icon panel and matching colour coded surround lighting mean its operation is visible to the technician from almost any angle. Clear **anti-counterfeiting** measures reassure workshops of an authentic Delphi Technologies device. Upon powering up the unit with a **CPU 5 times more powerful than its predecessor**, a technician can immediately benefit from intuitive software with a fresh look and feel. The future-ready unit brings to life new integrations such as **CAN FD** for improved, modern diagnostics with 3 CAN channels, and **DoIP** for the latest vehicle functions which are here to stay such as **telematics** and **ADAS**.

**"By making various diagnostic features integrated where they weren't before, we recognize workshops' need to have these functions at the ready for more and more models that have advanced technology as standard."** says Jean-Francois Bouveyron, VP for EMEA Aftermarket. "Workshops are maturing in their diagnostic journey and looking for similarly evolved diagnostic tools to boost workshop productivity, such as the Delphi Technologies' BlueTech VCI."

### CONNECTIVITY, SECURITY, AND SUSTAINABILITY IN ONE SOLUTION

The new diagnostic tool has a built in WiFi and communication encryption making the BlueTech VCI easy and secure to connect with, and access highly sought-after functionality. Security gateway allows the workshop to seamlessly service security protected vehicles and DTC-assist connects technicians with guided diagnostic assistance. Pass thru diagnostics is a bridge between all-makes diagnostics and OEM diagnostics for safety recalls and repair instructions.

Delphi Technologies' **market leading sustainability** programs help create a **cleaner**, more **efficient** world for customers, communities, and the planet. The new VCI is a small but powerful contributor to these sustainability efforts as it can help workshops serve **hybrid** and **electric** vehicles, provide **light duty** and **heavy duty** coverage in one device, and meet critical emissions standards. **"The BlueTech VCI also helps workshops fix it right first time and contribute to their own sustainability goals which are an increasingly more critical factor of vehicle maintenance and repair."** Comments Jean-Francois Bouveyron, "Customers want to know that their diagnostic investment for the workshop will grow as their business grows, and expand their service offerings to welcome new vehicles through the door in the future."

## BlueTech

Next generation diagnostics

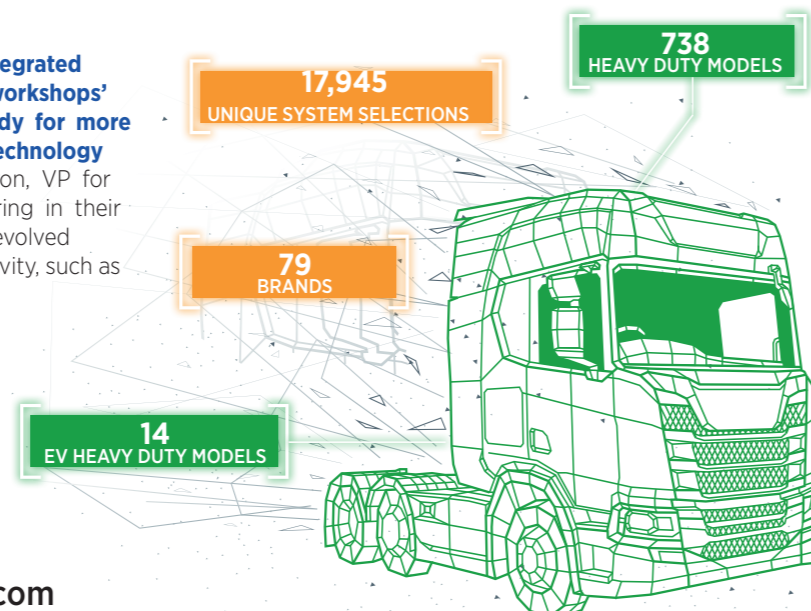

delphiaftermarket.com



Delphi Technologies is a brand of BorgWarner Inc.



# BlueTech



## Discover the next generation of diagnostics.

PASS- THRU SUPPORT | INTEGRATED DoIP | UNLOCK SECURITY GATEWAYS  
WIFI COMMUNICATION | CAN FD PROTOCOL

We believe every workshop should have access to the best **technology** and **functionality** required to carry out the **highest quality repairs**. Our new **BlueTech** VCI diagnostic solution combines advanced hardware and smart software to deliver a revolutionary and intuitive tool, enabling garages to maximize revenue and growth. **Welcome to the BlueTech experience!**



delphiaftermarket.com



Delphi Technologies is a brand of BorgWarner Inc.







Das Original

## A universe of information

The online and printed range from Elring – Das Original

The product range from Elring - Das Original is growing daily and ranges from exhaust manifold gaskets to cylinder head screws. In between are the familiar liquid sealants, as well as valve covers made from polyamide and, of course, all engine gaskets.

But it's not just the product range that has to be right, but the service too. To make the entire portfolio easy to find for the user and because the need for information has become more regional and product-specific in light of the major successes in the global market penetration over the past years, meaning that the range of information has been significantly expanded.

### Specific global and regional product information

This need is reflected in two commercial vehicle brochures for the DetroitDiesel DD15® engine, as well as the PACCAR MX13 engine, which are particularly popular in North America and Australia. Both are available to download in PDF format on the homepage.

To serve the commercial vehicle customers on the other side of the Atlantic, a 36 page brochure was produced for the HDEP engine range from Mercedes-Benz. For all 4 engine sizes from 11 to 16 litres, there are the exploded views of the engines, the OE part numbers, dimensions of gaskets and a wealth of other information. On the first pages of the brochure, you will find images of gasket sets specially compiled for these engines, which make service work on the engine significantly easier.

The range of gaskets for all other commercial vehicle engines available worldwide with corresponding exploded views can be found in the expanded commercial vehicle paper catalogue from 2021.

It sets the standard on the market with around 800 pages. All exploded views are also available to download individually in PDF format on the homepage.

But even in a heavyweight like the commercial vehicle paper catalogue, the professionals from Elring can't include all information that is important for the workshop or retail.

To resolve this issue, Elring offers the online catalogue that can be easily accessed via the website without registration. Here, visitors will find high-resolution images for gaskets and entire gasket sets that show even the smallest O-ring clearly. With over 16,000 individual references in the online catalogue, this is a truly mammoth task. For 75% of all parts, this task is already completed and, with this number of images, Elring is way ahead of the competition in the market for engine gaskets.

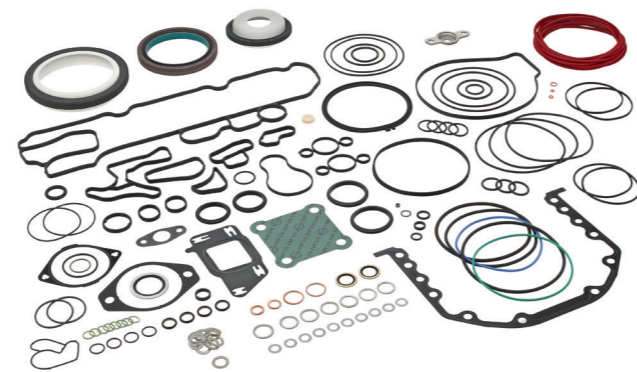

356.050, gasket kit, crankcase, Mercedes-Benz OM 470

For passenger car information requirements, a paper catalogue will remain available as in the past. The catalogue had to be divided due to the massively expanded portfolio. Combined, the two publications include 1,700 pages and 12,000 articles and weigh 8 Kg. This catalogue also sets standards. Due to the enormous amount of work that goes in to compiling the data and distributing the information worldwide, the current issue is from 2020. For 2023, we are working on a new and even more extensive project, meaning that we will most likely have a trilogy in place in 2023.

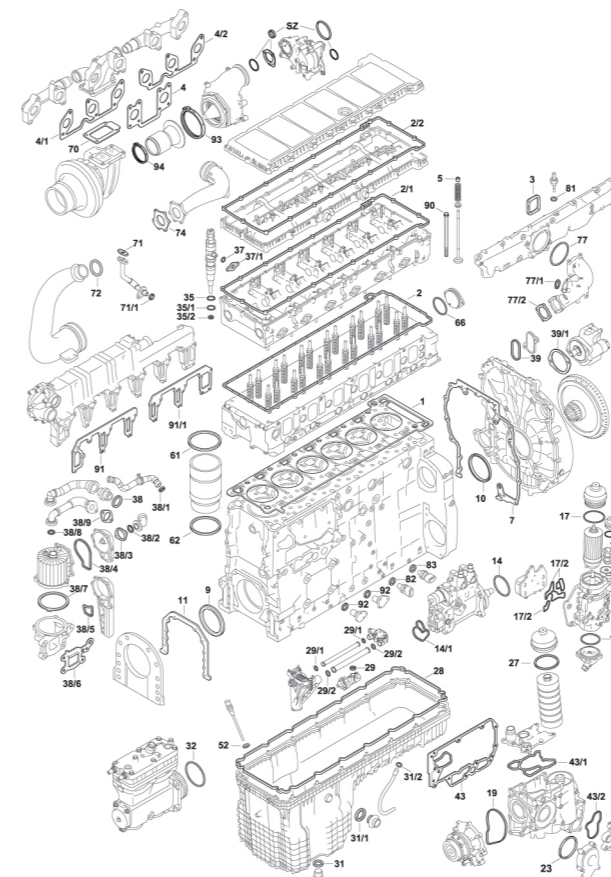

Detailed exploded views can be found online and in the commercial vehicle print catalogue.

### General Motors Small Block LS Engine – THE catalogue

Elring will be providing its customers with a 100 page catalogue in time for the leading aftermarket trade fair for North America, the AAPEX/SEMA Show in Las Vegas. For all three generations of the extremely popular engine series from General Motors, there are: Exploded views, all OE part numbers and important information on individual gaskets. Further catalogues are in preparation due to the excellent reception among the users.

### Something new every day

New engines are being developed constantly and result in an ongoing need for new engine gaskets. In order to reflect this situation, new products are added to the online catalogue daily, meaning that this medium is an up-to-date source of information for customers at all times. With around 1,000 new products added in 2021, the daily update is also the only way of managing this data.

Users will soon have the additional option of creating new products lists conveniently as an Excel download. There is also the option of filtering for specific vehicle manufacturers, selecting engines and product groups or selecting specific periods of time. All information can then be downloaded as an Excel or XML file. Because the search can be tailored to a much greater extent, it takes practice to get to the desired result, however. Anyone who wants to take an easier approach and would also like to stay up-to-date with other news can subscribe to the monthly newsletter. The newsletter lists new products added in the previous month, which can also be viewed via a link.

### What else does Elring offer?

The overhauled sealant consultant recently presented on our homepage is extremely popular, as reflected in the hit rates. The improved range of silicone sealants over the course of 2021, anaerobic sealants and the newly available sealant Curil™ T2 is extremely well received by all customers worldwide.

The "Elring – Das Original" YouTube channel is attracting an ever increasing number of viewers with its practical and entertaining videos. The channel enjoys an exceptional status with 36,600 subscribers and around a million views in the engine parts segment in 2021.

In future, Elring – Das Original will continue to expand its range of information to offer its customers the best possible service and set new standards.

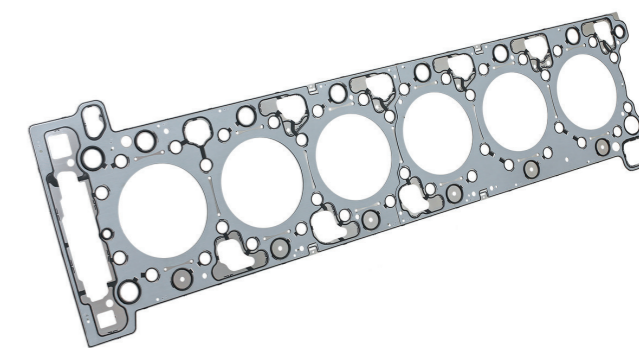

601.800 Cylinder Head Gasket



## EXIDE EXPAND ENDURANCE+PRO GEL RANGE FOR UNRIVALLED DEPENDABILITY



Exide Technologies is helping fleet operators to keep their business moving with the high performance VRLA (Valve Regulated Lead-Acid) GEL battery technology, pushing cycling endurance to new levels.

Leading commercial vehicle manufacturers know the great benefits of offering their end users the option of a dual battery system, combining specific Exide EFB technology for starting and GEL deep-cycle for on-board hotel loads. This virtually eliminates the risk of non-starting due to a discharged battery.

The aftermarket maintenance-free Exide Endurance+PRO GEL battery delivers far more cycling endurance than both SHD (Super Heavy Duty) flooded batteries and AGM (Absorbent Glass Mat) alternatives. This makes it ideal for high energy uses, such as long-haul trucks with 'life on board' equipment and commercial vehicles doing extensive urban deliveries. The battery achieves the deepest possible discharge for better energy availability, leading to prolonged life span.

	EXIDE ENDURANCE+PRO GEL		
	ED851T	ED2103	ED2103T
Standalone CV battery	■	■	■
Dual Battery System	■	■	■
Capacity Ah	85	210	210
CCA A (EN)	350	1030	800
Container	D02	D06	D06
L (mm)	349	518	518
W (mm)	175	279	279
H (mm)	235	240	240
Hold down	B0	B0	B0
Polarity	ETN1	ETN3	ETN3

Besides the **EndurancePRO** range, Exide offers fleet operators, parts distributors and service workshops a complete choice of CV batteries for every need:

**StrongPRO**, which features the next generation high vibration resistance design and comes with Carbon Boost, Exide's smart electrochemical solution for durability and faster recharging.

**PowerPRO, Agri & Construction** and **StartPRO**, each delivers the optimum combination of benefits to meet specific CV energy needs in terms of vibration resistance, cycling endurance and cranking power.

Exide makes it easy to find the right battery for your needs. Use our free Battery Finder app or online version to identify the correct fitment for most trucks, buses, tractors and agri-construction vehicles.



Michael Geiger, VP Sales & Marketing (EMEA) at Exide Technologies, said: "CV operators and their drivers rely on their batteries doing their job, without fail, every day and night. The cycling endurance demands of many long-haul and delivery trucks have grown enormously. Cranking-focused batteries are no longer the answer. We are therefore very excited to include our VRLA GEL batteries for high consumption vehicles that also contribute to operator peace of mind."

# The best start of the day.

## Exide Endurance+PRO GEL.



Ideal for commercial vehicles with a high demand for battery energy when the engine is switched off...but ready to restart at any time!

### Benefits of Exide Endurance+PRO GEL

- Impressive energy throughput over the battery lifetime: safe DoD of 90%, vs 50% of standard flooded batteries, and 5 times more cycles than a comparable standard flooded battery
- Withstands deep discharges for maximum reliability
- Valve regulated: maximum safety
- Vibration resistant
- Very low self discharge
- Maintenance free
- Designed for OE applications
- Specific types suitable for use in Dual Battery Systems in combination with Exide EFB

exidegroup.com



Available in D06 box

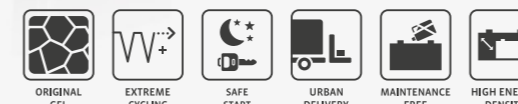

ENERGIZING A NEW WORLD



# A Clean Thing.

## NOx Sensors from febi

In diesel-powered commercial vehicles and passenger cars, the urea AdBlue® is used in conjunction with an SCR system (Selective Catalytic Reduction) for exhaust gas purification. AdBlue® is an aqueous solution of 32.5% synthetic urea and 67.5% demineralised water.

By reacting urea with the hot exhaust gases in an SCR catalytic converter, toxic nitrogen oxides are converted into harmless nitrogen and water vapour to meet the Euro 5 and higher exhaust emission standards.

To monitor the reduction process of harmful nitrogen oxides, NOx sensors (nitrogen oxide sensor) are installed before and after the SCR catalytic converter. They monitor the function and effectiveness of the SCR system by measuring the nitrogen and oxygen concentration in the exhaust gas. If a sensor fails, the engine control unit switches to a so-called emergency running programme.

Depending on the vehicle type, the engine speed and power are reduced. If the fault in the system is not rectified, in the worst case, the next workshop can only be visited at walking speed.



### Benefits at a Glance

- » Safe function thanks to excellent resistance to water, operating fluids, and corrosion
- » Long service life thanks to high-quality components with high resistance to vibrations and temperature fluctuations
- » Problem-free installation according to the vehicle manufacturer's specifications thanks to absolute fitting accuracy
- » Good price-performance ratio
- » Extensive product portfolio
- » 3 year manufacturer's guarantee
- » Inspected on installation test beds
- » Further replacement parts for SCR systems such as fuel filler caps, urea filters and exhaust gas temperature sensors in the febi product range

Discover our complete range of Fuel and Exhaust System technology:

[partsfinder.bilsteingroup.com](http://partsfinder.bilsteingroup.com)



# Quality from Start to Finish

with febi NOx Sensors

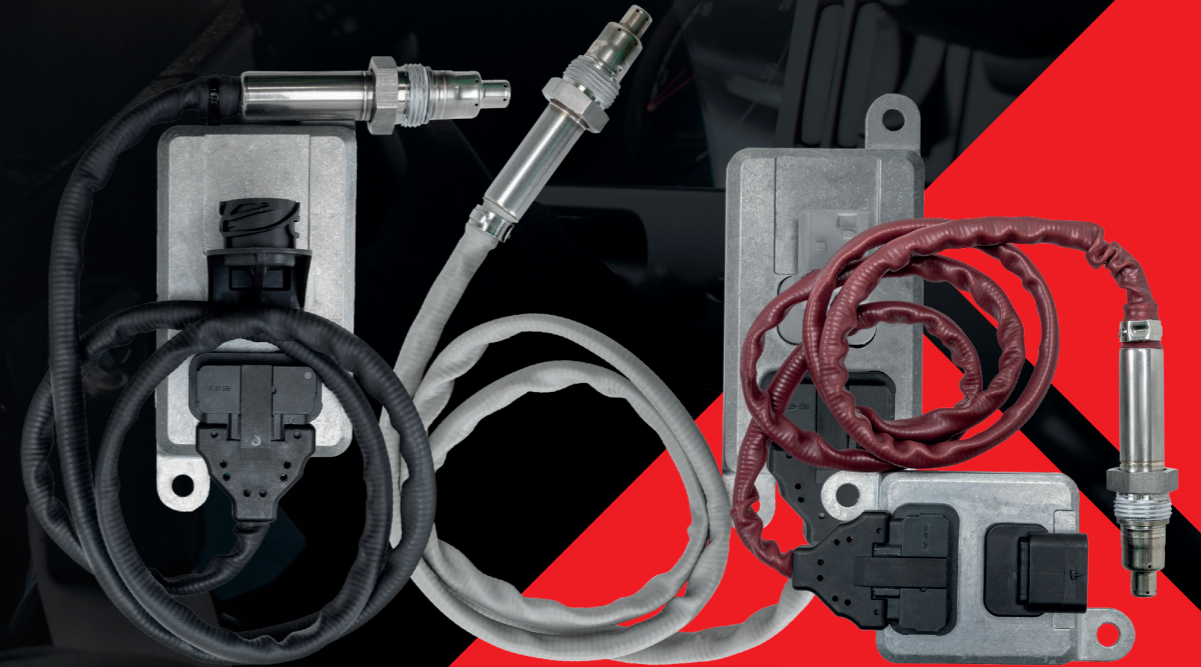

**SOLUTIONS**  
**MADE IN GERMANY**

[www.febi.com](http://www.febi.com)

**bilsteingroup®**



## HEAVY DUTY WATER PUMPS NOW AVAILABLE FROM GATES

Gates, a leading global provider of application-specific fluid power and power transmission solutions, has added belt-driven OE quality water pumps to its specialist range of aftermarket products for heavy duty trucks and buses.

Heavy duty water pumps have become part of the Gates FleetRunner™ range. Truck and bus operators will now be able to carry out a complete accessory belt drive system overhaul using heavy duty parts (water pump, coolant hoses, belt, tensioner and idler) covered by the Gates warranty.

Water pumps are among the key components powered by the drive belt. As a world leader in the design of heavy duty drive systems for the major truck and bus manufacturers, Gates has a strong OE pedigree. As an established water pump manufacturer, with a successful track record for supplying heavy duty water pumps in markets such as the US and Canada, Gates appreciates the particularity of fleet engineers when it comes to the quality of the drive system parts fitted to their fleets. The heavy duty water pumps in the FleetRunner range are an ideal fit for any preventive maintenance strategy.

Each Gates water pump unit is made from premium grade materials. A computer-tooled manufacturing process, with assembly lines that are subject to strict quality controls, ensures the water pumps all match or exceed OE quality standards and conform with various international standards (such as ISO/TS 16949). A precisely balanced impeller ensures OE fit and function. Finally, all units are subject to a rigorous leak-testing programme that checks all seals and bearings, as well as the individual casings.

For parts distributors, the new FleetRunner heavy duty water pumps offer a wide range of benefits, including the ability to stock parts for which there is already rising demand and an opportunity to supply water pumps covered by the extended Gates warranty programme.

Installers benefit from a first time fit and a comprehensive level of technical support, which often takes form via direct training or online training for workshop mechanics. In addition to basic fitting instructions and information around the importance of flushing out the cooling system after installation, the available technical support also extends to webinars that cover more complex areas such as cooling system diagnostics and how to maintain optimum coolant condition.

Bert De Lange, business development manager for Heavy Duty Aftermarket Sales and Marketing, for Gates Europe says: "Our initial range of FleetRunner heavy duty water pumps is well-researched and only stocked with popular applications that are already in demand. We will be able to cover over six million trucks and buses on EMEA roads from day one. That's all possible thanks to our OE drive systems development experience, coupled with water pump manufacturing expertise and extensive knowledge of the heavy duty drive systems markets."



### About Gates Industrial Corporation plc

Gates is a global manufacturer of innovative, highly engineered power transmission and fluid power solutions. Gates offers a broad portfolio of products to diverse replacement channel customers, and to original equipment manufacturers as specified components. For more than a century, Gates has pushed the boundaries of materials science to engineer products that exceed expectations in many sectors of the industrial and consumer markets. Our products play essential roles in a diverse range of applications across a wide variety of end markets including industrial on-highway, industrial off-highway, mobility and recreation, automotive, energy and resources as well as diversified industrial. Our products are sold in more than 30 countries across our four commercial regions: the Americas; Europe, Middle East & Africa; Greater China; and East Asia & India. More about Gates can be found at [www.gates.com](http://www.gates.com).



## HEAVY DUTY WATER PUMPS ALL NEW, NOW FROM GATES

### OE QUALITY WATER PUMPS ARE NOW PART OF THE FLEETRANNER RANGE

Gates designs belt drive systems for the world's major truck and bus manufacturers.

Now you can source everything you need to complete a heavy duty accessory belt drive system overhaul. Belts, tensioners, idlers, hoses, thermostats and now, a range of brand new belt-driven water pumps. When delivery schedules are tight and reliability is a must, source replacement parts for your fleet from a brand with a strong OE pedigree.

**FLEETRANNER, FROM GATES. FIRST CALL FOR AN OVERHAUL.**



[GATESTECHZONE.COM](http://GATESTECHZONE.COM)

GATES  
AUTOMOTIVE CATALOGUE

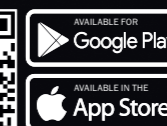

FOLLOW GATES AUTO



[GATESAUTOCAT.COM](http://GATESAUTOCAT.COM)



## Hengst outfits Daimler trucks with new oil coolant module.



### Fuel savings and extended service intervals for new heavy duty diesel engine DD15 Gen5.

Apart from being designed to cover extremely long distances, trucks are also exposed to extreme temperatures. Particularly taxing on the engines in this regard are exceedingly cold temperatures. The latest generation of Daimler's heavy duty DD15Gen5 engines lives up to these demands by delivering a boost in performance and less downtime. The oil coolant module from Hengst does its share by providing enhanced filtration properties that result in extended service intervals of up to 150,000 km. What is more, the module also offers an extremely high functional density and brings about significant savings in fuel.

Equipped with an optimized stack filter, the new oil coolant module engineered by Hengst is used in a great number of engines. The high functional density of the module comprises oil filtration, oil water heat management, water pump and, unlike the previous model generation, an oil pressure regulating valve.

**Fewer parts, lighter and more robust**  
By applying smart interface integration, Hengst was able to reduce the number of parts to a minimum. Even the oil thermostat has been incorporated directly into the housing. Overall, the reduction in parts has made the module 10% lighter than the

predecessor model. Better yet, the topology optimized design provides for greater sturdiness against pressure and pulsation and improves Delta P performance by 30%.

The extremely low temperatures that dominate the winter months cause the consistency of the engine oil to turn exceedingly thick and viscous. When it impacts the filter, this highly viscous oil generates an enormous differential pressure (Delta P). The latest generation of the Hengst stack filter has made it possible to achieve a significant increase in oil differential pressure. This causes the filter bypass

valve to open later, resulting in a considerable boost in filtration performance.

#### Improved differential pressure = less fuel and extended service intervals

Hengst has found the solution by developing the stack filter with its partially synthetic medium. Special intermediate plates embedded in the filter insert shorten the pleats, giving a significant boost to stability. At the same time, these plates keep the pleats open, thus keeping differential pressure and filtration performance at optimum levels. This most recent module generation combines a reduction in fuel consumption with significantly extended service intervals.

**The SMART Alternative.**  
OE quality and service excellence.  
[www.hengst.com/smart](http://www.hengst.com/smart)

**The SMART Alternative.**  
OE quality and service excellence.  
It is in the nature of things: There is only one original. We offer a service that makes things possible, flexible, reliable and personal – so that you can convince your clients with first-class OE quality and attractive conditions. As a strong sales partner with optimal availability.  
[www.hengst.com/smart](http://www.hengst.com/smart)



Professional products just for workshops  
www.liqui-moly.com

# THREE SMART WAYS TO INCREASE MARGINS AND SATISFY CUSTOMERS



**More than just motor oils: LIQUI MOLY offers an extensive range of chemicals for commercial vehicles**

Large volumes, great price pressure and low margins – this is often enough how the aftermarket business for commercial vehicles presents itself. The oil and additive specialist LIQUI MOLY offers three smart ways to increase margins and make customers more satisfied.

The first route is saving money through quality. LIQUI MOLY offers motor oils with official approvals from all relevant commercial vehicle manufacturers. Such an official approval is the highest award that an motor oil can receive. This means that not only the oil producer itself, but also the vehicle manufacturer stands behind the quality of the oil. Such an oil allows maximum change intervals, which increases the lubricant life. This compensates for the additional cost of the high-quality oil. LIQUI MOLY also offers fleet owners a special service: Oil analyses document the condition of the lubricant during use. LIQUI MOLY's quality promise also includes the fact that all oils are manufactured centrally in Germany – no filling plants in different countries that deliver varying qualities.

The second approach involves a smart choice of lubricant. LIQUI MOLY advises fleet operators to put together an individual lubricant range in which as many vehicles as possible are covered by as few different oils as possible. This simplifies procurement and logistics, and reduces the risk of expensive mistakes through reaching for the wrong oil. The third route



Super Diesel Additive prevents damage to injectors, removes deposits and increases the cetane number

goes beyond motor oils. LIQUI MOLY offers an extensive range of chemical products for commercial vehicles. There are other lubricants, such as gear oils and greases. There are additives that reduce wear, increase the service life of the engines and transmissions, reduce maintenance costs, avoid expensive repairs, and reduce unplanned down times. There are service products, such as brake cleaners and rust removers, that are essential in any workshop. And there are care products, such as rim cleaners and universal cleaners. LIQUI MOLY offers a complete range of chemicals for commercial vehicles – all from a single source for certain compatibility. This opens up a wide range of opportunities to build new business relationships with fleet operators, even if they do not intend to switch manufacturers of motor oil at first.



LIQUI MOLY offers a wide range of chemical products for commercial vehicles

LIQUI MOLY's core business is automotive, where the company can look back on 65 years of experience with chemical products. LIQUI MOLY brings this experience to bear on commercial vehicles. In this segment, the company has recorded above-average growth in recent years. Particularly in international business, it still sees a lot of potential and therefore plans to expand its distribution to further countries.

# Save money through quality

In the end, it's not a single purchase price that counts for fleet operators, but the total cost of ownership. LIQUI MOLY helps

- ✓ through individual analysis and cost reduction advice
- ✓ by restoring the original engine efficiency with additives
- ✓ by reducing maintenance and repair costs thanks to high-quality products

This offers new business opportunities to you and helps fleet operators to save money.



www.liqui-moly.com





[www.mahle-aftermarket.com](http://www.mahle-aftermarket.com)  
[www.mpulse.mahle.com](http://www.mpulse.mahle.com)

## MADE BY MAHLE



**160 locations in more than 30 countries—one quality standard: When you buy and install products from MAHLE, you can be sure you're holding a piece of German engineering excellence in your hands. It doesn't matter whether the packaging says Made in Turkey, Made in China, Made in Brazil, or Made in Germany. We produce our products for original equipment or the aftermarket around the globe according to the same processes and quality measures. So the result is always 100 percent MAHLE brand quality.**

You can find MAHLE products almost anywhere in the world. We operate globally in order to be close to our original equipment, trade, and workshop customers. Today, we produce MAHLE quality at 160 locations in over 30 countries—and each of our locations manufactures according to “Made in Germany” standards, with German engineering and know-how.

What's more, all MAHLE production plants are certified according to IATF 16949, and the vehicle manufacturers have audited and approved the production lines.

### Thorough quality inspection

“Good quality is crucial—we can always do everything a little better” was Ernst Mahle's guiding principle. And it still holds true today. Quality forms an integral part of the product development process, from the initial inquiry from the vehicle manufacturer to the start of production. In the manufacturing process itself, we rely on multistage quality controls and quality assurance according to OE standards. The product is checked after each production step. That's quite a challenge, because some products go through as many as 64 production steps. MAHLE employees also take random samples of parts from production to be measured and examined in detail in the lab. At the end of the process, a 100 percent final inspection is carried out.

Once manufactured, most products for the aftermarket find their way to our regional central warehouses. In the goods receiving area, all products undergo a manual visual inspection to identify any transport damage and screen out defective items. We also use technology to carry out spot checks on certain products, such as when measuring the ovality and gap clearance of piston rings. After that, any products that are also assembled, grouped into sets, or packed are subjected to another final quality inspection. Only then are our products ready to be shipped to the retailer and installed in your workshop.



Thermal management products  
for all types of drives.



No matter whether it's humming or buzzing under the hood.

Thermal management is becoming more and more important - and that with all drive technologies. We offer workshops all thermal management spare parts plus workshop equipment and diagnostics for cars and commercial vehicles, vans, construction and agricultural machinery. With more than 9,000 quality articles, MAHLE Aftermarket completely covers the areas of air conditioning and engine cooling. With MAHLE, your workshop delivers 100% performance, today and tomorrow.

[mahle-aftermarket.com](http://mahle-aftermarket.com)





## Greater health and road safety: Perfectly equipped for the spring with the new MANN-FILTER FreciousPlus

- Cabin air filter FreciousPlus filters harmful particles and viruses
- Protects against harmful gases and stops odors
- Anti-allergenic and antimicrobial protective function
- Filter changes in accordance with the service schedule important for proper purification



MANN-FILTER FreciousPlus cabin air filter for commercial vehicles

A cabin air filter changed at the correct intervals is vitally important, especially in spring, when the peak pollen season begins, because it filters pollen and released allergens from incoming outside air, ensuring you can breathe freely. Global filtration specialist MANN+HUMMEL, based in Ludwigsburg Germany, provides effective protection against polluted air with its MANN-FILTER FreciousPlus cabin air filters in original equipment quality.

A vehicle ventilation system draws in huge volumes of air from outside the vehicle into the driver's cab. Every hour, several hundred thousand liters of this polluted outside air pass through the vehicle's ventilation system into the driver's cab, bringing with them not only allergens but also particulate matter, nitrogen oxides, and other harmful gases that pose a threat to the health of the driver. This means that the air in the interior of the vehicle is often much more polluted than the ambient air. Thorough purification of the outside air by means of a cabin air filter is therefore essential, especially for professional drivers. The current situation with COVID-19 again highlights the importance of clean ambient air, as infectious particles can be transported and transmitted through the air with aerosols. However unlike the

wearing of a face covering, a cabin air filter does not count as "personal protective equipment." It provides cleaner air in the vehicle interior and thus should be regarded as an additional protective measure. However, a cabin air filter can only carry out its meticulous cleaning task properly if it is replaced at the right time in accordance with the service schedule.

### MANN-FILTER FreciousPlus: high-performing and reliable

The FreciousPlus cabin air filter improves the air quality thanks to its different layers. In addition to coarse particles such as dust and tire wear dust, it also filters harmful particulate matter with an aerodynamic diameter of less than 2.5 micrometers (PM2.5). These tiny particles are roughly 70 times smaller than the width of a human hair and can penetrate deep into the lungs. It virtually completely adsorbs unpleasant odors and harmful gases like nitrogen oxide and ozone from the airflow. The biofunctional and antimicrobial coating on the FreciousPlus also traps the allergens which can be released from pollen, filters viruses, and has been proven to reduce the growth of microorganisms such as molds and bacteria.

### A quick and easy upgrade

MANN-FILTER supplies the FreciousPlus in customary OEM quality. For many vehicles, the filter upgrade is an easy one. When changing the filter the mechanic inserts the more effective FreciousPlus instead of the old cabin air filter, with no additional effort required. Due to the high mileage in the commercial sector, the cabin air filter should be changed every six months to operate at full efficiency. Professional drivers, wholesalers, vehicle fleet operators and workshops can find out all about the FreciousPlus and its features as well as find the right cabin air filter for their particular vehicle online at [www.frecious-plus.com](http://www.frecious-plus.com).



## Safer driving with MANN-FILTER!



Modern vehicles are becoming safer all the time. Besides an array of safety systems, airbags and safety belts are two of the main devices that protect us in a worst case scenario. But people often forget the invisible threats when driving: particulates, allergens, toxic gases, bacteria and fungal spores. A high-performance cabin air filter stops these unwelcome guests from getting into the inside of our vehicles, and from there into our lungs. Make sure to change your cabin air filter regularly for additional safety and peace of mind. Always choose original MANN-FILTER products in 100% OE quality.

**MANN-FILTER – Perfect parts. Perfect service.**  
[www.mann-filter.com](http://www.mann-filter.com)





# MERITOR® REMANUFACTURING: WHERE QUALITY COUNTS



With the increased global focus on sustainability and recycling, remanufacturing is becoming more and more popular. The automotive aftermarket has a long tradition of remanufacturing major components and even safety related items such as brake calipers are accepted, and sometimes favoured by end users. A quality remanufactured component offers OE equivalent performance while giving cost benefits as well as saving on raw materials and energy.

## INTEGRITY STANDARDS

		Meritor Standard	Safety Related
Structural Integrity	Bolt Grade	Tensile strength rating to match OE.	Yes
	New Bolts	100%	Yes
	Bolt Tightening Torques	As per original design specifications.	Yes
	Replacement Parts	OE or tested and approved to Meritor specifications - no 'off the shelf'.	Yes
	Sealing	100% new seals and gaskets. Seated correctly. No water ingress.	Yes
Performance Integrity	Running Clearance	0.7 to 1.2mm	Yes
	Tappet Synchronisation	Product type dependent - as per original design specifications.	Yes
	Potentiometer Setting	Set in accordance with Knorr information and setting tool.	Yes
	Bearing Surfaces	Clean, free from wear and pitting.	Yes
	Cleanliness/Contamination	Caliper free from dirt, rust, shot and other all contamination.	Yes
	Lubrication	Grease to OE specification, clean and free from contamination.	Yes
Other	Packaging	5 Ply Double Wall industrial cardboard - Banded.	No
	Traceability	Securely attached Meritor plate, production code engraved into plate, or on unit, and packaging.	No
	Cosmetics	All rust, dirt removed. Unit painted in Meritor Red.	No

Not all Reman calipers are the same. And Meritor ones are truly the best.

Meritor remanufactured brake calipers come with the backing of OE technical expertise, they are produced in efficient, fully industrialised remanufacturing facilities using the latest techniques.

They are engineered to the highest standards designed to give you peace of mind.

Meritor uses its extensive engineering capability to ensure that the performance of a Meritor Remanufactured product is equal to or better than the original.

### NON MERITOR PRODUCTS

- 3D Scanning
- Modelling
- Material Analysis
- Reverse Engineering
- Design Review
- Part validation against known vehicle test requirements

### MERITOR DESIGNED PRODUCTS

- OE Design intent review
- OE Manufacturing process application
- OE Parts
- OE Production testing

[www.meritorpartsexpress.com/eu](http://www.meritorpartsexpress.com/eu)



# MERITOR® REMANUFACTURED BRAKE CALIPERS WARRANTY EXTENSION

As a supplier of Original Equipment brakes to major truck and bus manufacturers, Meritor understands what it takes to design and build brake calipers to the highest standards. We use this knowledge and experience to give you exceptional quality remanufactured brakes for aftermarket use.

Meritor is pleased to announce the extension of its warranty to **2 YEARS UNLIMITED KM/M** on all Meritor Remanufactured brand calipers.



©2022 Meritor, Inc



www.metalcaucho.com/en

## Hoses and expansion tanks for trucks, a new business line of Metalcaucho

The Metalcaucho's determination to continue growing and expanding the offer to his customers has made to take another step forward in the rubber and metal sector. That is why Metalcaucho presented a new product family a year ago, truck parts.

Metalcaucho, european leading supplier of aftermarket spare parts in rubber and metal for the automotive sector started this new business line launching 213 part numbers, and then they has been adding more codes until reaching 218 codes for a long list of manufacturer brands: Astra, DAF, ERF, Irisbus, Iveco, John Deere, MAN, Mercedes-Benz, Neoplan, Renault Trucks, Scania, Setra and Volvo.

This Spanish company, owned by BBB Industries, the industry's leading American remanufacturing company, has in its portfolio models from different categories of trucks, buses, and even tractors are included.

The 218 part numbers, that Metalcaucho have compiled in a specific catalog on their website, are divided into the following product families:

\* Hoses for:

- Radiator = 123 part numbers
- Turbo = 28 part numbers
- Heating = 14 part numbers
- Hydraulic Steering = 1 part numbers
- Oil = 14 part numbers

- \* Expansion tanks = 25 part numbers
- \* Expansion tank caps = 13 part numbers

### Metalcaucho ensures the quality of all its products

In Metalcaucho they **exhaustively control the entire process**, from the design and development of the initial sample to serial production, and implement post-sale follow-up mechanisms to give a quick response to their customers

Quality is an essential requirement in all the processes and solutions. That is why they use **the same composition of materials and production processes as in the original parts:**

For **cooling hoses**, they use EPDM (Ethylene Propylene Rubber), which has **great flexibility at low temperatures and good chemical resistance**, which makes it a perfect material for transporting cooling liquid.

For **turbo hoses**, different types of rubbers are used:

- **AEM** (Ethylene / Acrylic Elastomer): has good resistance to hot mineral oils, fluids and wear and tear.
- **FKM** (Fluorocarbon): is resistant to high temperatures (max. 232°C), so they are used as an internal layer.
- **VQM** (Silicone): has excellent mechanical resistance and high temperatures (max. 225°C).
- **FVQM** (Fluorosilicone): offers resistance to fuel and mineral oil, ideal for providing a chemical reinforcement.

For **expansion tanks**, they are manufactured in PP (Polypropylene) in which between 5% and 30% of Ethylene is added to obtain an ethylene copolymer, and thus the tank can offer **greater mechanical resistance** than one with a conventional Polypropylene.

Metalcaucho has invested 3.2% of its turnover in a new laboratory for the Quality Department, in which they carry out rigorous controls to which all their products are subjected, guaranteeing high reliability, equivalent to original equipment, but with more competitive cost.



## Truck spare parts

### New product family

#### Hoses for:

- Radiator
- Turbo
- Heating
- Steering
- Oil

#### Expansion tanks Expansion tank caps

**218**  
part numbers





www.nrf.eu  
webshop.nrf.eu

## NRF MANUFACTURES A FULL RANGE OF EURO 6 RADIATORS



NRF is a manufacturer. In their own production facilities, they produce a wide range of engine cooling and climate control parts, including a full range of Euro 6 truck radiators.

In addition, the product inlets and outlets are protected to prevent contamination from outside.

When it comes to trucks, there are two main requirements: reliability and durability. At NRF you can be sure that you are ordering a high-quality aftermarket part. To ensure the high quality, NRF has strict engineering, production, quality control and testing processes.

### MANUFACTURER OF HIGH QUALITY TRUCK RADIATORS

NRF radiators are produced on advanced product lines. NRF uses high-quality raw materials. During the engineering process, NRF ensures that all measurement and connection points are correct. If necessary, NRF adds additions, such as solid X-frame for reinforcement, as can be seen in the DAF radiator photos.



NRF RADIATORS FOR DAF CF/XF  
NRF NO. 50153 / 50154

### EXTENSIVE TEST PROCEDURES

Before adding a radiator to the NRF range, all radiators are extensively tested. These tests include leak tests, pressure tests, and vibration tests. These tests simulate real-life operating and road conditions.

### STRONG AND SOLID PACKAGING

NRF parts are always delivered in strong and solid boxes, resulting in optimal protection during storage and transport.

## NRF INTRODUCES TRUCK EXHAUST GAS TEMPERATURE SENSORS



NRF makes a huge step in its aftermarket offer. NRF is going beyond engine cooling and climate control with their new product group, Exhaust Gas Temperature Sensors (EGTS). By expanding their offer, NRF moves in line with market demand. NRF EGTS are manufactured on tested and validated production lines. This results in a highest quality product at competitive aftermarket prices.

NRF introduces a range of 200 sensors for passenger cars, light commercial vehicles, trucks and buses. Scan the QR code to learn how these sensors work.

### EASY FIT = SUPPLIED WITH HIGH TEMPERATURE GREASE

In addition, NRF EGTS have another unique advantage. All NRF EGTS are Easy Fit, as they come with High Temperature Grease. By applying this specific grease during installation, friction is prevented and correct assembly is guaranteed.



NEW TO RANGE

## TRUCK EXHAUST GAS TEMPERATURE SENSORS

TOTAL  
RANGE OF  
**200**  
SENSORS



NRF NO. 707012 > DAF XF

EMPOWERING PERFORMANCE



[www.osram.com/truckstarpro](http://www.osram.com/truckstarpro)

# OSRAM TRUCKSTAR® PRO BUILT FOR THE LONG HAUL

**OSRAM**

**Truck and commercial vehicle drivers are pushed to their performance limit every time they get behind the wheel, and so are their lights. As owners, drivers, and fleet managers, you rely on the performance of your lights to keep you safe, day in day out. For you, exceptional quality is the minimum requirement. Lighting systems must therefore be powerful and durable enough to keep up with the demands of your job.**

## Performance & durability you can rely on

OSRAM has been turning night into day for over 110 years. With a history of pioneering technology and a future full of game-changing innovations, you can rely on proven performance from the OSRAM family of products. OSRAM products are rigorously tested under the most extreme conditions to ensure every lamp exceeds all ECE quality requirements. Their commitment to continual innovation is focused on developing quality automotive lighting solutions that improve the driver's vision and the visibility of all road users.

## TRUCKSTAR® PRO is the most powerful range of halogen truck lights from OSRAM

There's no room for error in commercial driving. With many hours spent behind the wheel, often at night and in bad weather, the slightest lapse in concentration can have serious implications for drivers and their cargo. As daylight fades, subconscious control functions begin to diminish, conscious reaction times can be slowed down, and driving becomes more stressful. Furthermore, driver fatigue and poor visibility are potential safety risks. OSRAM TRUCKSTAR® PRO lamps offer up to 2,5 more lifetime<sup>1</sup> and up to 120% more brightness<sup>2,3</sup>, making it easier for you to focus on the road ahead. These impressively bright 24-volt lamps are built with vibration resistant technology to handle heavy duty applications and their excellent durability helps reduce downtime and fleet costs.

## Maximum value for your business

At OSRAM, they understand the importance of proper vehicle maintenance. Every minute spent in the workshop is revenue lost. That's why OSRAM lights are developed especially with the needs of professionals in mind. They offer extra-long lifespan, optimized light intensity and vibration resistance. This means less downtime and more productivity, as well as significant savings on lamps and costs each year.

Use the TRUCKSTAR® PRO calculation tool ([www.osram.com/truckstarpro](http://www.osram.com/truckstarpro)) to work out your individual annual requirement for replacement lamps and find out how much money you can save by installing TRUCKSTAR® PRO lamps. On average three TRUCKSTAR® PRO lamps will replace five standard 24 Volt lamps. The longer life of TRUCKSTAR® PRO lamps alone – averaging 1200 hours compared with 650 hours for standard 24 Volt lamps – will save you money. All you have to do is enter the number of trucks in your fleet, the average number of days on the road and a few other values and you'll be amazed. Enjoy huge cost savings compared with conventional 24 Volt lamps.

**Whatever you need to get the job done, OSRAM's range of high-performance solutions are built to last, giving you the confidence to tackle any road in the toughest conditions. Trust OSRAM to light your way.**



<sup>1</sup> Compared with standard lamps  
<sup>2</sup> H1, H4, H7 and H11  
<sup>3</sup> Compared to minimum ECE R112 requirements

[osram.com/truckstarpro](http://osram.com/truckstarpro)



## Bringing light to business

# OSRAM TRUCKSTAR® PRO

## Built for the long haul

Ideal for professional drivers, the impressively bright 24-volt lamps of the TRUCKSTAR® PRO are built with vibration resistant technology to handle heavy duty applications. Their excellent durability helps reduce downtime and fleet costs. OSRAM's most powerful range of halogen truck lights offers up to 2,5 more lifetime<sup>1</sup> and up to 120%<sup>2,3</sup> more brightness – giving you the confidence to tackle any road in the toughest conditions. **Insist on OSRAM – the No.1 in Automotive Lighting.**

Light is OSRAM



<sup>1</sup> Compared with standard lamps. <sup>2</sup> H1, H4, H7 and H11. <sup>3</sup> Compared to minimum ECE R112 requirements



philips.com

# PHILIPS LED WORK LIGHTS

## DESIGNED WITH YOU IN MIND

Philips Xperion 6000 range has what it takes to get any job done perfectly

The Philips Xperion 6000 LED work light range helps you see almost anywhere you need while offering long-lasting durability, flexibility and battery lifetime that lets you work at your best.

Brighter illumination, longer lasting

Multiple light modes and the flexibility of an additional spotlight or hose light across the range means superb visibility, no matter how difficult the working environment. A beam angle of up to 110° provides widespread coverage of your working area. In addition, all Philips Xperion 6000 work lights use 6000 K LEDs. A single charge via the USB Type-C socket, which gives the high-capacity battery sufficient power to last the working day in different modes.

IK07 impact resistance shields them from the inevitable knocks and drops that happen at work. Water splashes, dust, grease, workshop solvents and most chemicals are kept at bay thanks to ingress protection rated IP54 or higher. Finished in hard-wearing ABS copolymer and rubber, the lamps are more than a match for the rigors of a typical automotive workshop.



Smart, ergonomic design

A touch of thoughtful design further enhances the functionality of the Philips Xperion 6000 range. Equipped with integrated magnets and a 360°-rotatable hook, these LED work lights can be simply and securely attached to a metallic surface or suspended above the work area, leaving both hands free for the job. Rotatable light units allow even greater flexibility for directing the beam precisely where it's required.

As even the most careful mechanics might forget where they left their tools, the Philips Find My Device accessory offers a failsafe solution for tracking down compatible misplaced lamps. Serving as both a cordless charging station and a convenient storage point, the Philips Multi Dock Station keeps your LED work lights ready to go. An LED indicator blinks while charging and turns green when the devices are fully charged.

For further details, go to: [www.Philips.com/Xperion-6000](http://www.Philips.com/Xperion-6000)



Xperion 6000

LED work lights

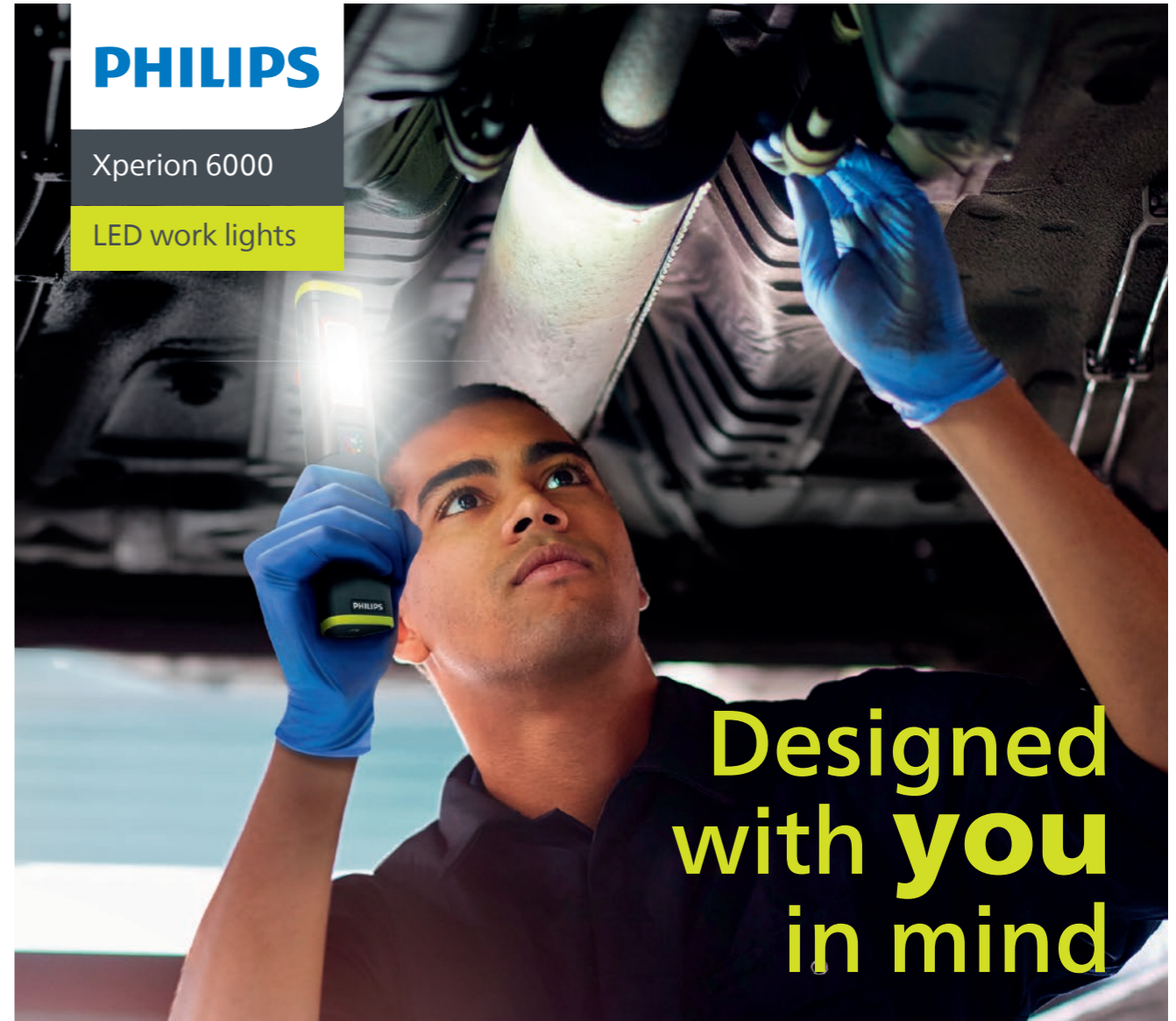

Designed with you in mind

### Advanced lighting performance that lasts

Discover our brand-new Philips Xperion 6000 work lights, designed with you to handle any daily tasks in tough environments.



UV Pillar



Pillar



Pocket



Slim



Line

innovation + you

[Philips.com/Xperion-6000](http://Philips.com/Xperion-6000)



## Clutches for trucks and buses: Valeo Euro 6 range

Valeo offers a broad range of clutches produced to the highest standards to limit emissions and meet Euro 6 regulations.

### Euro 6: A regulation limiting exhaust emissions

It's common knowledge that the ongoing gradual phase-out of fossil fuel vehicles is having a positive impact on climate change and air pollution. What you may not be aware of is that the progress on this front starts far earlier, and that all trucks and buses sold in Europe over the last few decades have had to comply with emissions standards set by the European Commission.

The first round of the European exhaust emissions regulations, commonly known as Euro 1, came into effect in 1992. Today, vehicles follow Euro 6 emissions standards introduced on 31st December 2012 and EU regulators are already working on Euro 7, which should be announced by the end of 2021 and will likely come into force in 2025.

### Emission standards for trucks and buses

Trucks and buses both fall under the official category of "heavy-duty diesel engines". The emission standards for these vehicles are defined by engine energy output in g/kWh, as opposed to the emission standards for passenger cars and light commercial vehicles, which are defined by vehicle driving distance in g/km.

Euro 6 regulations incorporate tough monitoring of high-temperature combustion emissions that contain nitrogen and oxygen, NO and NO<sub>2</sub>, together known as NO<sub>x</sub>. These regulations also control how much carbon monoxide, hydrocarbon and particulate matter vehicles can emit per kilometre driven.

Over the years, the targets for emissions reduction have become increasingly strict: The Euro 6 limits currently in force are 95% lower in NO<sub>x</sub> and 98% lower in particulate matter emissions than the Euro 1 limits set in 1998.

This increasingly narrow tolerance for dangerous emissions has led to much automotive industry innovation; Euro 6 standards have made trucks and buses cleaner, more fuel efficient and, in some cases, more powerful than ever before.



### How is Valeo meeting these targets ?

Valeo, as the leading supplier of clutch components, produces its commercial vehicle clutch range to the highest quality standards and specification requirements. The components on offer have also, of course, evolved over the years, in accordance with Valeo's sustainability commitments and the latest regulations.

Valeo clutches use the best technologies available with TH disc and F830 linings. The New Valeo TH clutch disc is a solution that contributes to reducing fuel consumption and meeting emissions standards. The Valeo friction material approved by O.E. manufacturers is the best-in-class solution to avoid judder effects, noise and vibrations on Euro 6 robotised gearboxes. It ensures the transmission of higher engine torque (up to 3500 Nm) with the best driver comfort and enhanced durability as it avoids unnecessary gearshifts.

Today, Valeo offers the most comprehensive range of clutch components on the market, adapted to meet all requirements. It comprises more than 80 references in total, including new and remanufactured components for both robotised and manual Euro 6 gearboxes. The Valeo range covers the most popular applications for many major Truck and Bus manufacturers such as: DAF LF, CF & XF, Iveco Stralis & Eurocargo, MAN TGL, TGM, TGS & TGX, Mercedes Actros, Antos, Arocs & Atego, Renault Trucks T, K, C & D, Scania L, P, G, R & S and finally, Volvo FE, FL, FM, FMX, & FH models.



# NETWORK CONTACTS



LEADING NETWORK  
OF INDEPENDENT GARAGES  
FOR TRUCKS & TRAILERS  
IN EUROPE AND BRAZIL

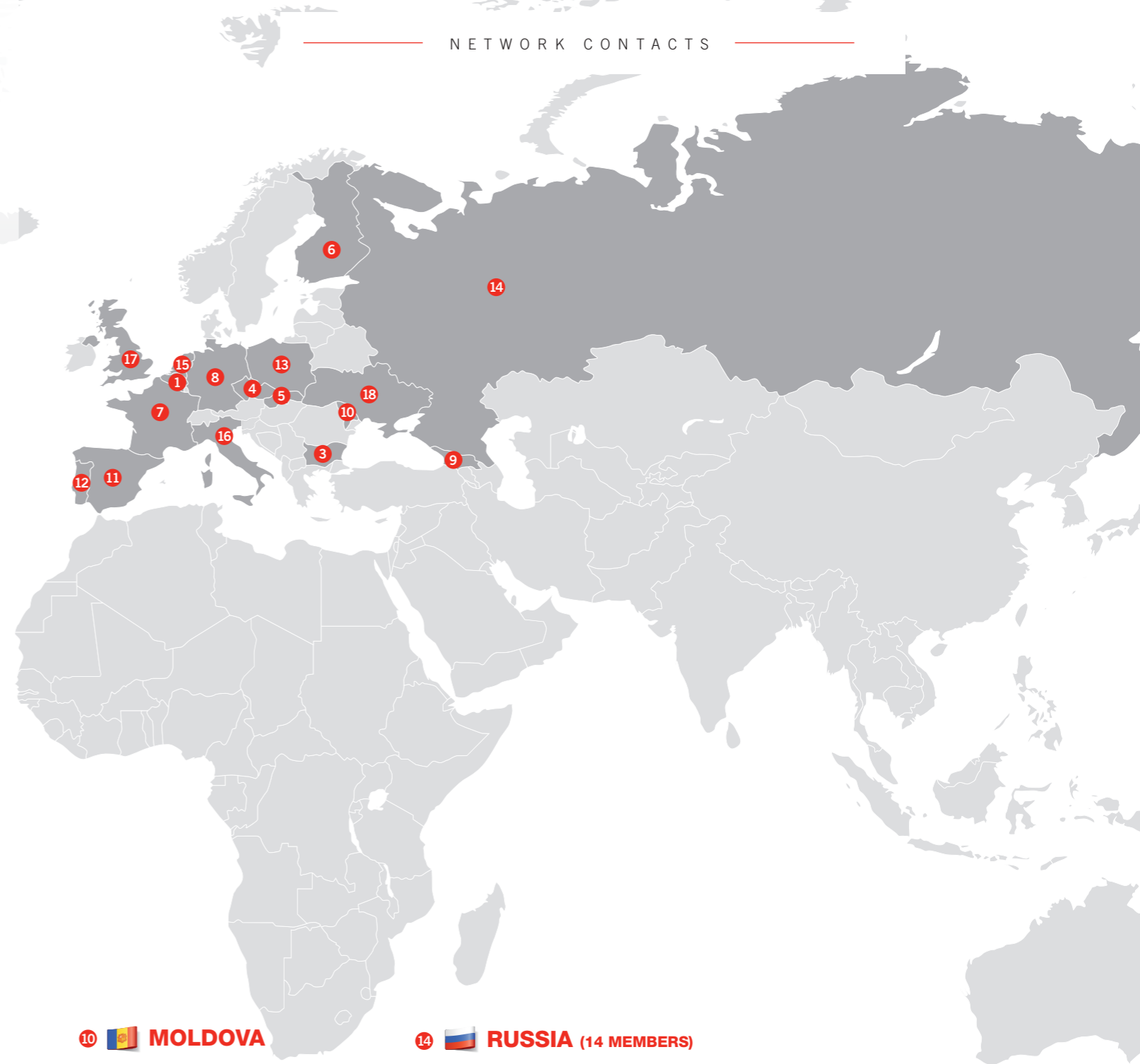

## NETWORK MEMBERS

**1 BELGIUM (6 MEMBERS)**

Frits Wernsen  
frits@toptruck.nl  
Phone: +31 263760590  
Mobile: +31 6 20474868

**4 CZECH REPUBLIC (20 MEMBERS)**

**5 & SLOVAKIA (2 MEMBERS)**

Peter Trnavsky  
trnavsky@emt-czech.cz  
trnavsky@emt-slovakia.sk  
Mobile: +420 266 100 245

**2 BRAZIL (126 MEMBERS)**

Paulo Fabiano Navi  
Paulo.Navi@distribuidora.com.br  
Phone: +55-11-31557044

**6 FINLAND (42 MEMBERS)**

Samy Olin  
samy.olin@koivunen.fi  
Phone: +358 50 468 1013

**8 GERMANY (114 MEMBERS)**

Dirk Wittenberg  
wittenberg@coparts.de

**3 BULGARIA (13 MEMBERS)**

Georgi Tchetinov  
office@groupauto.bg  
Phone: +359 2 9208580

**7 FRANCE (206 MEMBERS)**

Jerome Brunner  
j.brunner@allianceautomotive.fr

**9 GEORGIA (6 MEMBERS)**

d.tsakadze@groupautocaucasus.com  
Phone: +995 591 707 181  
Mobile: +995 595 366 464

**10 MOLDOVA**

Aleksey Vinogradenko  
aleksey.vinogradenko@groupauto.md  
Phone: +373 22 815 464

**14 RUSSIA (14 MEMBERS)**

Igor Ponomarev  
i.ponomarev@groupautorus.ru  
Mobile: +7(495) 7475183

**11 SPAIN (120 MEMBERS)**

**12 & PORTUGAL (19 MEMBERS)**

Jesus Camara  
jcamara@groupautounion.es  
Phone +34 91 541 77 54  
Mobile +34 628 108 700

**15 THE NETHERLANDS (54 MEMBERS)**

Frits Wernsen  
frits@toptruck.nl  
Phone: +31 263760590  
Mobile: +31 6 20474868

**17 UNITED KINGDOM (50 MEMBERS)**

Maria McCullough  
maria.mccullough@groupauto.co.uk  
Phone: +44.01274 470279  
Fax: +44.01274 654610  
Mobile: 07860 439171

**13 POLAND (14 MEMBERS)**

Andrzej Guzek  
andrzej.guzek@groupautopolska.pl  
Phone + 48 22 292 83 80  
Mobile + 48 790 800 829

**16 ITALY (182 MEMBERS)**

Stefano Baruzzi  
s.baruzzi@truckcompany.it  
Phone +39 02 89696877  
Fax +39 02 2135751  
Mobile +39 335 5476585

**18 UKRAINE (33 MEMBERS)**

Yana Yavtushenko  
yana.yavtushenko@vladislav.ua





# Innovation in every part.

## Brake Components



Brake Caliper



Brake Pads



Brake Discs

## Telematics Unit



## Clutch Components

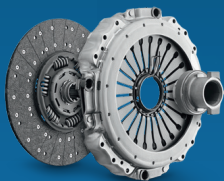

Disc Cover Releaser

## Shock Absorbers

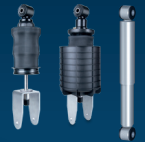

## Transmissions



ZF Ecosplit



ZF Ecofluid



ZF AS Tronic

## Drive Axle

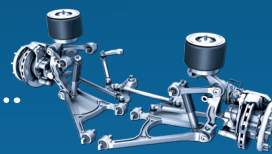

## Steering and Suspension Components



AFTERMARKET

LEMFÖRDER  SACHS  TRW 