

SCHAEFFLER

We pioneer motion

Technologies for Commercial Vehicles

Innovative. Sustainable. Efficient.



Challenging targets are setting new trends.

The automotive industry bears a great responsibility in shaping a sustainable society. The requirements are high: The **CO₂ fleet targets** for newly registered commercial vehicles defined by the European Commission call for a reduction in CO₂ emissions of 15 % by 2025 and 30 % by 2030¹.

The **transition to alternative fuels** as well as **battery electric drives and hybridization** bring challenges but also opportunities. Additionally, increasing the efficiency of the powertrain and weight reduction play a decisive role in achieving these goals. **Autonomy and digitalization** raise new safety challenges, which need to be addressed responsibly.



California announced zero-emission targets for truck sales: 30 – 50 % by 2030 and 40 – 75 % by 2035²

CO₂ fleet targets

15 %

reduction in
CO₂ emissions by 2025

30 %

reduction in
CO₂ emissions by 2030

- Strict HD toxic emission regulation rollout worldwide
- California's new pollutant regulation for 2024
- USA preparing new norms for 2027
- Euro VII expected in the upcoming years



Until 2025, around 45 % of newly procured public buses will have to be zero- or low-emission vehicles in EU. By 2030, the targets increase up to 65 %³.

Sources: **1.** EU: Regulation 2019/1242 setting CO₂ emission performance standards for new heavy-duty vehicles, June 2019 | **2.** CARB: Advanced Clean Trucks Regulation, June 2020 | **3.** EU: Clean Vehicles Directive (2019/1161), June 2019

Empowering Transportation.

Our in-depth knowledge of innovative technologies enables us to fulfil our mission: **Empowering Transportation**. Integral to empowering transportations are solutions, which further drive progress in commercial vehicles.

We provide sustainable solutions and services for:

- ⚡ **Electrification**
- ↓ **Emission reduction**
- 📄 **Digitalization**
- 🛡️ **Safety**

We make motion and mobility more efficient and intelligent. Therefore, around **8,000 employees in 20 R&D centers** develop new products, technologies and processes.

For nearly 100 years, we have been taking responsibility as a supplier to the powertrains of commercial vehicles. And with more than **70 million truck bearings per year**, we have become a **recognized partner in the industry**.

Global Innovator. Local Partner.

Schaeffler offers an exceptionally wide range of manufacturing expertise and **modern technologies for maximum economy, precision and reliability**. With a high level of vertical integration, we manufacture precision products in 75 plants around the world. With 170 subsidiaries we are globally close at your hand when it comes to individual solutions.

In December 2019, Schaeffler Group and ABT e-Line started a collaboration to further drive the development of electric drive systems as well as vehicle integration and assembly with focus on light commercial and special vehicles. The collaboration is an integral part to contribute to the Sustainable Development Goals (SDGs) of the United Nations.

*True to our motto **We pioneer motion**, at Schaeffler we empower commercial transportation. With our deep technical system know-how and growing product portfolio we want to be the preferred supplier for our customers and support them in meeting the enormous challenges of the industry.*



Matthias Zink,
CEO Automotive Technologies
at Schaeffler

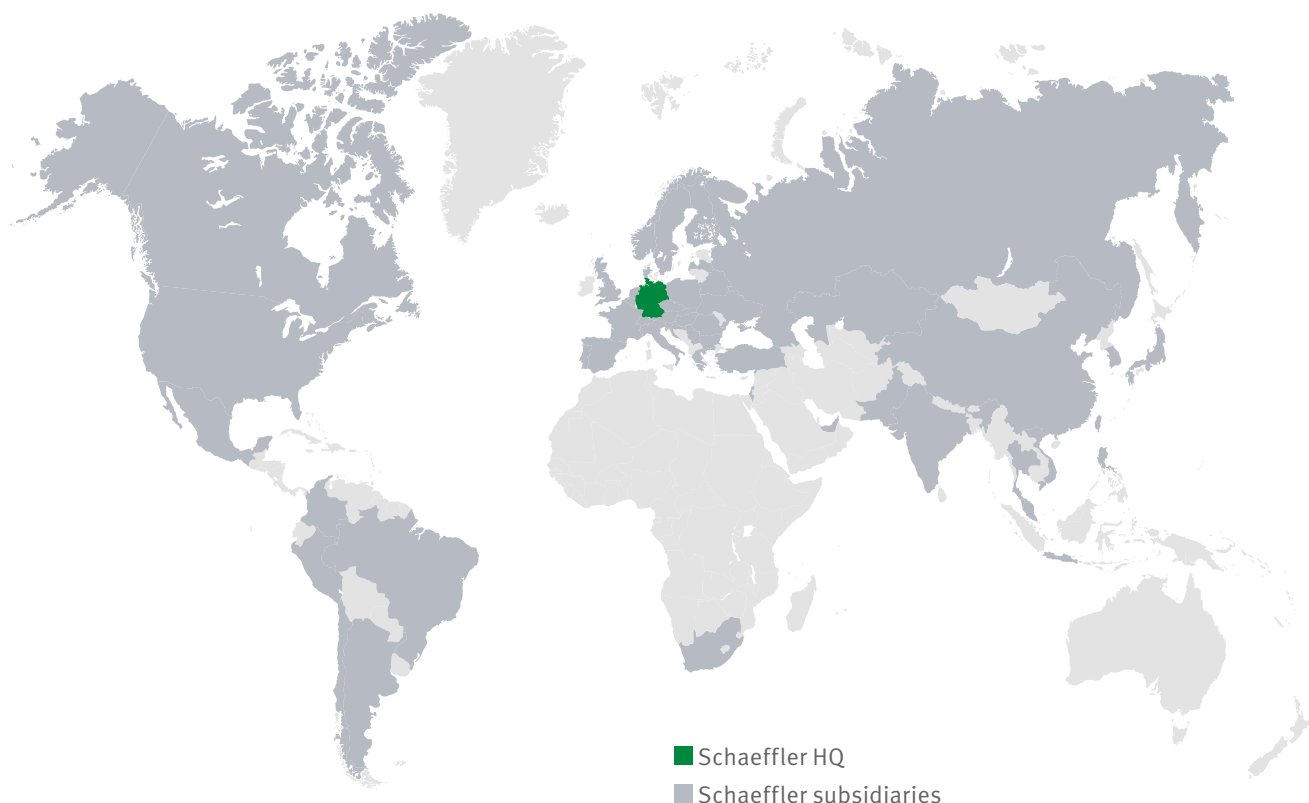

Electrification

Electrification is needed for the achievement of our emission targets. Schaeffler supports your powertrain with e-motors, power electronics and fuel cell technologies.

With our goal of achieving maximum sustainability and CO₂ neutrality, Schaeffler is shaping mobility and the associated energy chain. Our innovative technology platform provides the necessary variance in the modular electric motor system. With the high vertical range of manufacturing, many years of production expertise and future-oriented winding technology, Schaeffler electrifies solutions with the highest power density, maximum performance and quality.

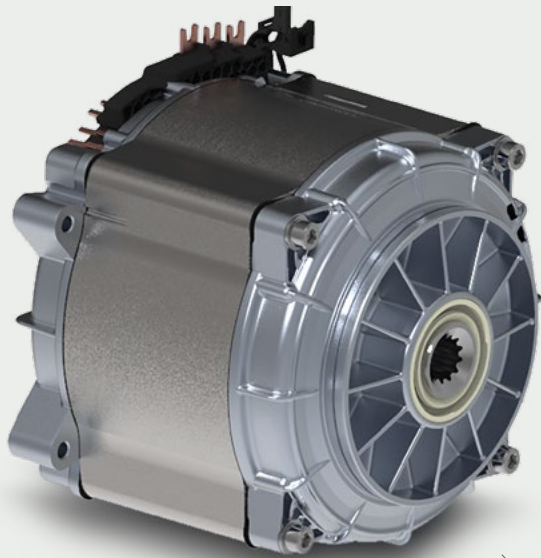

HV E-Motor

E-Motors and Power Electronics

Our E-Motors and Power Electronics are dedicated to continuous power for commercial vehicles. Scalable in speed and torque, our HV solutions can be optimized for central drives or e-axles. Our 48V E-Motor uses concentrated winding for compact design, compatible with standard transmissions. The robust and scalable PEU uses SiC technology for high efficiency.

- HV E-Motor
- 48V E-Motor
- Power Electronics Unit



Fuel Cell Coolant Valve

Thermal Management Components

Fuel cells require a precise air and coolant flow control under all ambient conditions. Our valves and TMM modules offer smart control solutions for coolant and air flow with a well-proven rotary valve concept and a proprietary actuator. Our battery cooling concept ensures a homogeneous temperature profile for all cells inside the battery.

- Thermo Management Module
- Control Valve
- Coolant Valve
- Heavy-Duty Battery Cooling System

Fuel Cell Systems & Components

Schaeffler's core expertise in materials technology, forming technology and surface technology enables the efficient high-volume production of key components for the future hydrogen economy with high power density.

- System Competence
- Bipolar Plates
- Fuel Cell Stacks
- Foil Bearings
- Thermal Management
- Control Units

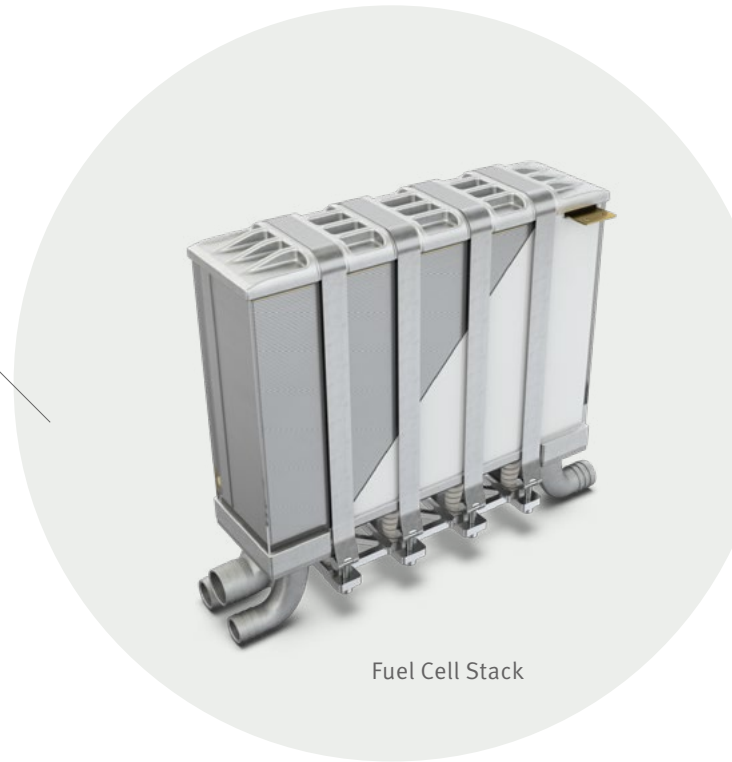

Fuel Cell Stack



E-Motor Bearing

Bearing Solutions for E-Motors

Our new series of high-performance Deep Groove Ball Bearing are especially optimized for high rotational speeds and suitable for rotor shaft bearing supports of electric machines. Available for both oil lubrication as well as in greased and sealed version.

Emission Reduction

Save energy and cost while reducing CO₂ and pollutants with our engine and powertrain technologies.

Less material wear and longer service life, lighter and innovative parts and components lead to even higher energy efficiency and lower emissions and costs. Particularly during the long-term transition to gas fuels as well as to battery electric and hybrid drives, measures such as weight reduction and increasing the efficiency of the combustion engine play a decisive role in achieving these goals economically.

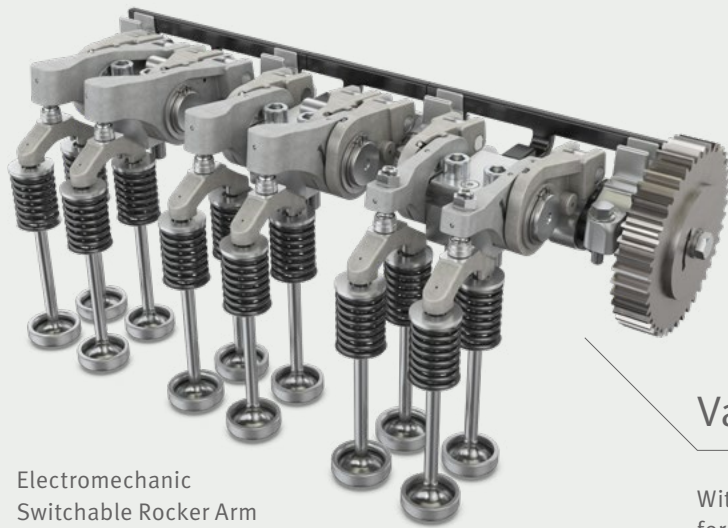

Electromechanic
Switchable Rocker Arm
(IP Rail)

Valvetrain System & Components

With our valvetrain components we offer efficient solutions for the challenges of commercial vehicles. IP-Rail offers variability in the valve train for cylinder deactivation, engine brake and Miller cycle, supporting your CO₂ reduction, pollutant and safety needs. Our Hydraulic Lash Adjuster (HLA) makes lash adjustment maintenance-free, reduces noise and leads to lower emissions throughout the whole lifetime.

- Rocker Arm With Hydraulic Lash Adjuster (HLA)
- Sheet Metal Valve Bridge
- Electromechanic Switchable Rocker Arm (IP Rail)

Powertrain System Optimization

Downspeeding leads to higher excitation in the drivetrain. PYD and OAP enable a reduction in FEAD preload to achieve lower power loss and longer lifetime. For the transmissions, the CPA allows lower rpm which results also in lower CO₂ emission and NVH.

- Centrifugal Pendulum Absorber (CPA)
- Crankshaft Pulley Decoupler (PYD)
- Overrunning Alternator Pulley (OAP)



Crankshaft Pulley
Decoupler (PYD)

Bearing Solutions for Transmissions

Increased power density and load capacity, less friction, higher durability, higher resistance to low oil levels, but less in size and costs: All these benefits describe our bearing solutions for transmissions. Achieve your performance and cost saving targets at once.

- Needle Roller Bearings
- Thrust Needle Roller Bearings
- Planetary Gear Bearings
- One Way Clutches, e.g. for Oil-Pump
- Ball Bearings for Transmission
- Tandem Ball Bearings (TBB)
- Tapered Roller Bearings (TRB)



Needle Roller Bearings

Bearing Solutions for Engine



Ball Bearing Cartridge for Turbocharger and Turbocompound

We offer innovative bearing solutions to reduce friction in challenging load positions and environments. This leads to an increased acceleration in turbo cartridges and lower friction in camshaft and timing drives. Our Water Pump Bearings enable variability to save CO₂.

- Ball Bearing Cartridge for Turbocharger
- Ball Bearing Cartridge for Turbocompound
- Crankshaft Main Bearing
- Bearings for Timing Drives
- Throttle Valve Bearings
- Double Decker Water Pump Bearing for variable water pumps
- Standard Water Pump Bearing
- Water Pump Impeller

Axle & Wheel Bearing Solutions

Recent compact & lightweight final drive and wheel bearings offer up to 60 % less power loss resulting in significant fuel and CO₂ savings of 1 % beside their high service life. The tire inflation module gives additional CO₂ savings and reduces tire wear.

- Wheel Bearing Solutions
- Differential/Pinion Bearing
- Tire Inflation Module (TIM)



Wheel Bearing Solution (insert unit assembled in a cast iron hub)



Digitalization

Digitalization and Connectivity are changing the commercial vehicle industry. We provide solutions for the next level of digitalization.

The mobility of the future will be digital and driven by Big Data. New technologies such as the Space Drive drive-by-wire system are becoming increasingly important. We can utilize our specific knowledge of standardized production and thus optimize the entire supply chain. Our intelligent and interconnected products are equipped with sensors, electronics and actuators, which can supply information and be seamlessly integrated.



Space Drive

System and Components for ADAS & Autonomy

Redundant control units and integrated ADAS solutions for automotive series production. Retrofit solution Space Drive by Schaeffler Paravan offers a fail operational digital drive-by-wire system (steering, braking, acceleration and secondary functions). Official approvals and homologation for public roads without speed restriction.

- Redundant Control Units
- Space Drive

Connectivity Solutions

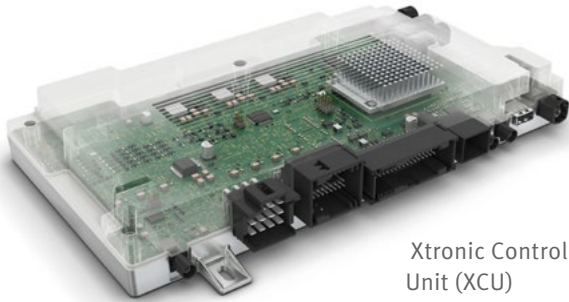

Xtronic Control Unit (XCU)

The XTRONIC Control Unit (XCU) is the central control system of the vehicle's superstructure or its trailer. It enables cross-system communication and complete connectivity of the vehicle's body and its components. These are customer-specifically configured. Synchronized user interfaces offer maximum comfort and safety. Through a cloud-based digital twin, the XCU simply connects everything. It extends existing interfaces with an easy configurable and digital solution.

Control Units

The PROtronic TargetLINE from Schaeffler Engineering is a prototyping and series control unit in one using reusable function blocks. These include qualified housing and connectors from mass production, validated and qualified hardware function blocks and software modules with a high degree of maturity already tested in the field.

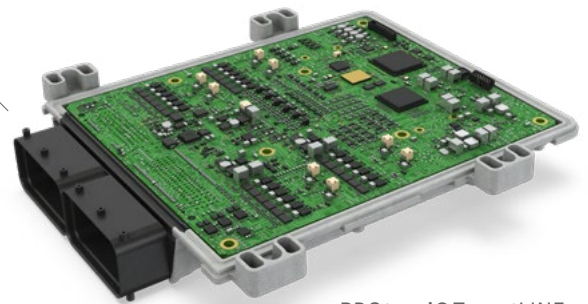

PROtronic TargetLINE

Sensor Platform

Our contactless automotive proven sensors provide monitoring for predictive maintenance and safety with highest reliability and durability. Magnetic Torque Sensors can be used in various positions in the drivetrain, e.g. in the gearbox. Our rotary and linear position sensors offer highspeed measurement for steering and other applications.

- Torque Sensor
- Linear Position Sensor
- Rotary Position Sensor



Torque Sensor

Reliability & Safety

Reliability and safety are the base for success in commercial vehicle industry. With Schaeffler products people can trust in vehicles.

Driver safety is the highest priority at Schaeffler. Moreover, we take responsibility to care for your investments, sustainability and environmental protection. Our many years of experience in chassis and accessory bearings are enabling us to contribute to commercial vehicles' durability and lower emissions. Key factors are our high competences in simulation with the constant R&D for safety and efficiency.

Chassis & Accessory Bearings

We offer dedicated bearing solutions for lifetime and safety-relevant applications. One example is our half-shell bearing for heavy-duty air disc brakes, which demonstrates durability as well as maximum load capacity in the smallest space.

- Half Shell Bearings
- Universal Joint Bearings
- Drive Shaft Support Bearings
- King Pin Bearings
- Needle Roller Bearings
- Brake Adjusters
- ABS Sensor Rings



Clutch Solutions

Comfort and robustness for applications in all torque classes: Our clutches with self-adjusting wear compensation, torsion dampers optimally matched to the drive train, and friction linings with low wear and high picking resistance.

- Clutch Systems including Release Bearings
- Clutch Actuators



Travel Adjusted Clutch

Torque Converter Systems

Perfect drive dynamics, low fuel consumption: Our new generation of converters with a mass-optimized sheet steel construction, advanced damper technology and precise clutch control for commercial vehicles automatic transmissions offers maximum efficiency during launch, gear shifting and steady state operations.



Torque Converter

Full Lifecycle Services



We are with you from the idea to series production and support you with aftermarket solutions.

At Schaeffler, the highest quality in components and service is the basis of all our activities. Delivering unique solutions for the automotive world – we're developing tomorrow's solutions today and continually evolving as a company at the same time. Our experts in engineering and validation can support you starting from the first idea until series production. Technical safety is key in all our processes, holistic safety constructs and structures from a single source.

Schaeffler Engineering

Schaeffler Engineering GmbH has been involved in the development of alternative drives for more than 20 years. Together with our system and series competence, this experience forms the basis for supporting customers from the heavy-duty sector in their current and future challenges – from the concept phase to series production.

Development for classic or alternative drive systems, hybridization and electrification of heavy-duty drives as well as function and electronic control unit development for high-level vehicle controls are part of our heavy-duty service portfolio. In addition, there is a test field for classic and alternative drives to develop and further improve solutions.



Schaeffler Automotive Aftermarket

The Automotive Aftermarket Division of the Schaeffler Group is responsible for the global spare parts business and delivers innovative repair solutions in original equipment quality. All components are original parts and work perfectly together. For the repair case optimized designs and pre-assembled solutions avoid mounting errors or dirt contaminations and help to reduce fitting times.

Under its LuK brand, Schaeffler offers a broad portfolio of clutch solutions from single components to complete sets, always aiming for extending the lifetime. Schaeffler's INA products cover trustworthy engine and transmission applications. The FAG brand represents Schaeffler's outstanding range of wheel bearing and differential products, covered by resource saving repair solutions for all designs and meeting the OEMs highest standards. With the Schaeffler REXPART service brand, the aftermarket specialists set a top priority on offering comprehensive services to garages. Those include practical-oriented training seminars, repair assistance via a specific hotline and the REXPART online portal.



Schaeffler Technologies AG & Co. KG

Industriestraße 1 – 3
91074 Herzogenaurach
Tel.: +49 (0) 9132 82-0
Fax: +49 (0) 9132 82-4933
www.schaeffler.com
info@schaeffler.com

Schaeffler Automotive Aftermarket GmbH & Co. KG

Paul-Ehrlich-Straße 21
63225 Langen
Tel.: +49 (0) 6103 753-0
Fax: +49 (0) 6103 753-295
<https://aftermarket.schaeffler.com>
aftermarket@schaeffler.com

Schaeffler Engineering GmbH

Gewerbestraße 14
58791 Werdohl
Tel.: +49 (0) 2392 809-0
Fax: +49 (0) 2392 809-100
<https://www.schaeffler-engineering.com>
info@schaeffler-engineering.com

Schaeffler Social Media

 @schaefflergroup
 @schaefflergroup
 @schaefflergroup
 @company/schaeffler/
 @schaeffler
 @pages/schaeffler

All data have been prepared with a great deal of care and checked for their accuracy but no liability can be accepted for any errors or omissions. We reserve the right to make technical modifications.

© Schaeffler Technologies AG & Co. KG

Issued: 2021, January
Reproduction in whole or in part without our authorization is prohibited.